



Cold Chain Solutions

Electronic solutions that help you achieve your refrigeration goals



Cold Chain Solution:

Food Service, Beverages, Pharmaceutical Applications

Overview / Introduction

Emerson – Retail Solutions offerings are utilized in the majority of food service operations around the world, driving refrigeration systems and providing monitoring solutions. Emerson’s Retail Solutions enable food service operators to reduce operational costs, protect food quality, and maximize equipment uptime. Overall, Emerson offers the breadth of facility solutions to dramatically improve a food service operator’s profitability.



E-CLASS CX Series: Basic Refrigeration Controllers

- Reduced number of parameters, easy and intuitive programming mode
- Keyboard lock, alarm display
- Also for application with reduced mounting depth (only 50 mm)
- Increasing temperature display delay
- Neutral zone management
- Built-in gasket (IP65)



FEATURES	XR01CX	XR02CX	XR03CX	XR04CX	XR06CX
Power supply	12, 24 Vac/dc 110, 230 Vac	12, 24 Vac/dc 110, 230 Vac	12, 24 Vac/dc 110, 230 Vac	12, 24 Vac/dc 110, 230 Vac	12, 24 Vac/dc 110, 230 Vac
Depth	50 mm	50 mm	50 mm	50 mm	59 mm
Probe inputs					
Thermostat	NTC	NTC	NTC	NTC	NTC
Defrost				NTC	NTC
Digital inputs					
Alarm, start defrost, AUX, door switch, pressure switch	config	config	config		config
Relay outputs					
Compressor	8A, 20A opt	8A, 20A opt	8A, 20A opt	8A, 20A opt	8A 16A 20A opt
Fans				8A	8A
Light					8A
AUX			8A		5A
Other					
Hot Key output	•	•	•	•	•
Buzzer	opt	opt	opt*	opt*	opt

*: available only with 8A compressor relay

XR01CX XR02CX

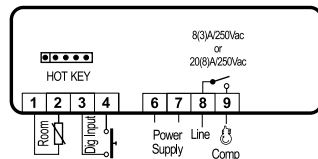

XR03CX

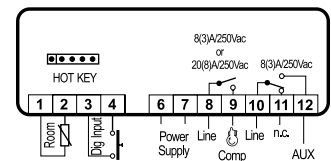

XR04CX

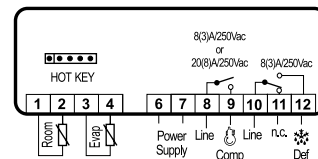

XR06CX

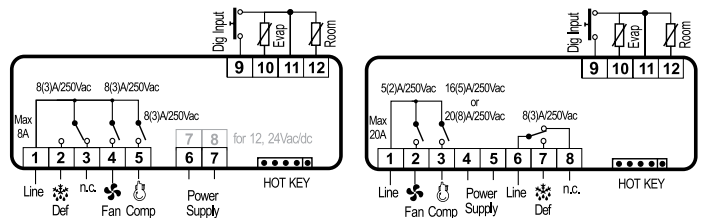

E-Class CH Series: New Innovation of E-Class Family

Same features as E-Class CX but with:

- New look and feel
- New terminal blocks
- Larger display
- Water drip protection with MDP/E-CH



FEATURES	XR01CH	XR02CH	XR03CH	XR04CH	XR06CH
Power supply	12, 24 Vac/dc 110, 230 Vac	12, 24 Vac/dc 110, 230 Vac	12, 24 Vac/dc 110, 230 Vac	12, 24 Vac/dc 110, 230 Vac	12, 24 Vac/dc 110, 230 Vac
Depth	50 mm	50 mm	50 mm	50 mm	59 mm
Probe inputs					
Thermostat	NTC	NTC	NTC	NTC	NTC
Defrost				NTC	NTC
Digital inputs					
Alarm, start defrost, AUX, door switch, pressure switch	config	config	config		config
Relay outputs					
Compressor	8A, 20A opt	8A, 20A opt	8A, 20A opt	8A, 20A opt	8A 16A 20A opt
Fans				8A	8A
Light					8A
AUX			8A		5A
Other					
Hot Key output	•	•	•	•	•
Buzzer	opt	opt	opt*	opt*	opt

*: available only with 8A compressor relay

XR01CH XR02CH

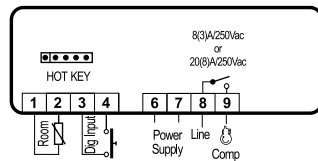

XR03CH

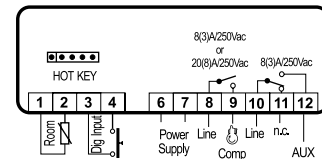

XR04CH

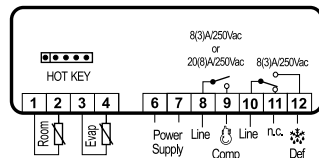

XR06CH

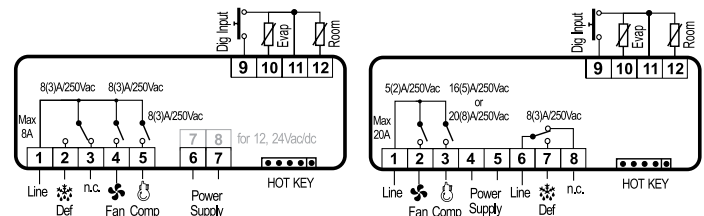

XRB Series: Bottle Cooler Applications (Standard version)

- Electronic controllers for bottle cooler
- Easy and intuitive installation
- High energy saving thanks to load optimization
- Algorithms for energy saving work without the use of external sensors
- Energy saving based on pre-set time interval
- Automatic setpoint management after filling the cabinet
- Compressor working time control
- Counters of compressor/defrost/fans/light activation time
- Condenser monitor for maintenance management
- Anti-sweat heaters management (only for XRB07CH)
- Firmware update via special Prog Key
- Hot Key or Prog Tool Kit connector for quick and easy programming
- Serial connection to monitoring systems



FEATURES	XRB04CH	XRB06CH	XRB07CH
Display: n° digits	± 3 d.p.	± 3 d.p.	± 3 d.p.
Power supply	12, 24 Vac/dc 110, 230 Vac	12, 24 Vac/dc 110, 230 Vac	12, 24 Vac/dc 110, 230 Vac
Probe inputs	NTC NTC NTC NTC on HOT KEY	NTC NTC NTC NTC on HOT KEY	NTC NTC NTC NTC on HOT KEY
Digital inputs	config	config	config
Relay outputs	16A	16A 20A 8A 8A 8A 5A	16A 8A 8A 5A
Other	Hot Key/Prog Tool Kit output Serial output Buzzer RTC	pres TTL opt opt	pres TTL opt opt

XRBO4CH

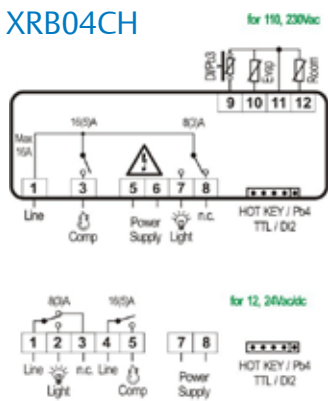

XRBO6CH

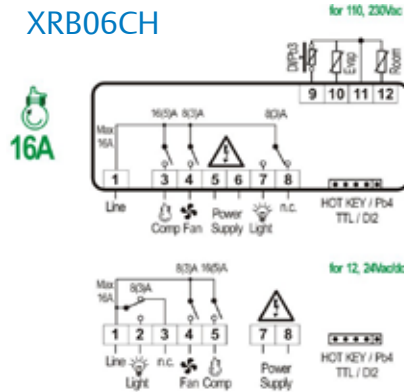

XRBO7CH

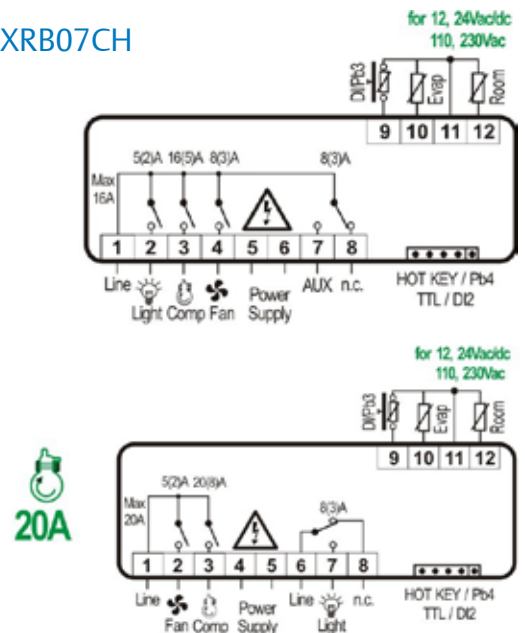

XR Series: Bottle Cooler Applications (Enhanced version)

- Advanced energy saving algorithms (PATENTED)
- Automatic defrost management (PATENTED)
- Auto-tuning
- Compatible with low GWP refrigerants
- Automatic extra cooling
- Multimap
- Real time clock (optional)
- Service counters (relay activation, working hours)
- Upgradable Firmware
- ModBUS serial communication



FEATURES	XR30CH	XR60CH	XR70CH
Display: n° digits	± 3 d.p.	± 3 d.p.	± 3 d.p.
Power supply	110, 230Vac	110, 230Vac	110, 230Vac
Probe inputs	up to 2 x NTC*	up to 4 x NTC**	up to 4 x NTC**
Digital inputs	up to 2 x configurable*	up to 2 x configurable**	up to 2 x configurable**
Relay outputs	16+8A	16+8+8A / 20+8+5A	16+8+8+5A
External port	HOT KEY, TTL	HOT KEY, TTL	HOT KEY, TTL
Terminals	screw or plug-in	screw or plug-in	screw or plug-in
Buzzer	Optional	Optional	Optional

** Up to 3 NTC when the digital inputs are configured as probe
 ** Up to 4 NTC when the digital inputs are configured as probe

XR30CH

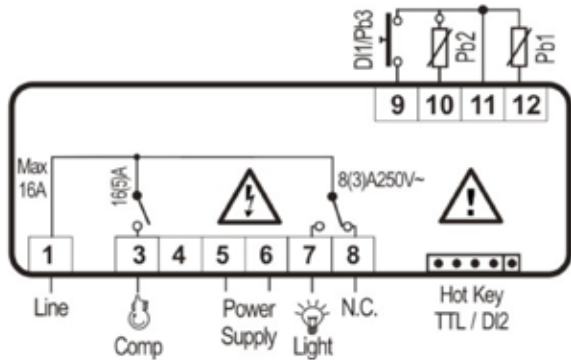

XR60CH

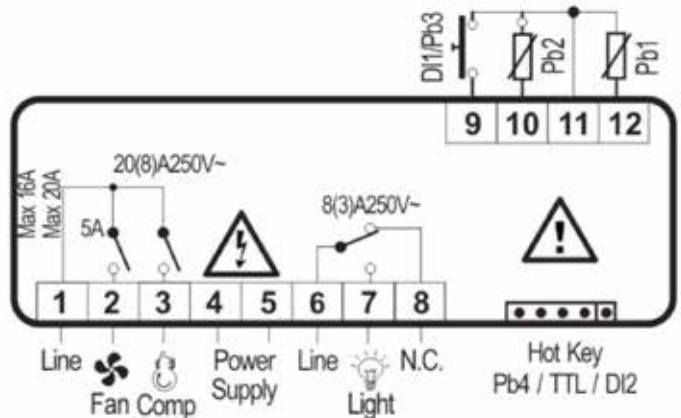

XR70CH

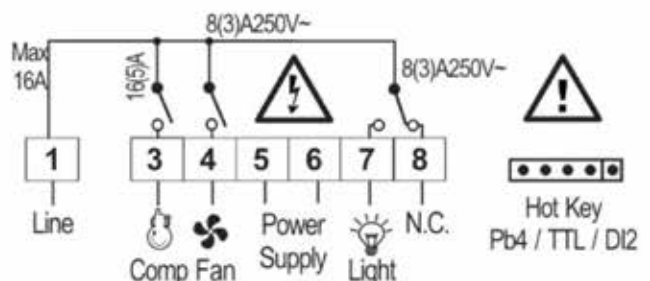
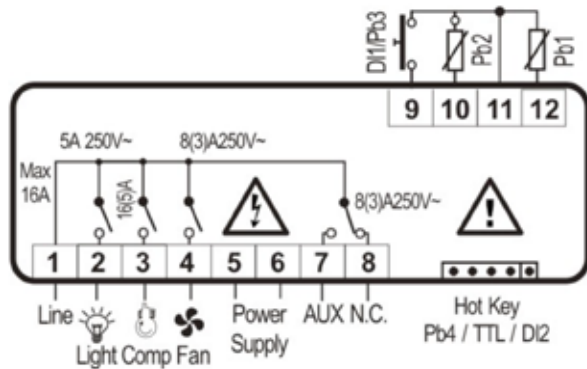

Prime CH and Wing LH Series: Refrigeration Controllers



- User friendly interface
- Direct access to the main functions
- Easy and intuitive installation
- Specific functions for pastry cases (dual humidity)
- Regulation based on the average of two temperatures
- Hot key or prog tool kit connector for quick and easy programming
- Serial connection to monitoring systems

PRIME CH & WING LH Series are the innovative & aesthetical solution controllers designed for commercial refrigeration, food service, and catering applications that guarantee high usability and quality food storage. When the aesthetic appeal becomes fundamental, these controllers are particularly appreciated for their sleek design and elegant style.

- Ice Cream Freezers
- Pastry Refrigerators
- Cold Rooms
- Warming Cabinets
- Refrigerated Cabinets
- Wine Cellars
- Showcases
- Refrigerated Counters



Prime CH

FEATURES	STATIC APPLICATIONS			VENTILATED APPLICATIONS				XR77CH	
	XR20CH	XR30CH	XR35CH	XR60CH		XR70CH	XR75CH		
Keyboard: push buttons	6	6	6	6	6	6	6	6	
Power supply	12, 24Vac/ dc110, 230Vac	12, 24Vac/ dc110, 230Vac	110, 230Vac	12, 24Vac/dc 110, 230Vac	110, 230Vac	110, 230Vac	12Vac/dc	110, 230Vac	12, 24Vac/ dc110, 230Vac
Probe inputs									
Thermostat	NTC, PTC	NTC, PTC	NTC, Pt1000	NTC, PTC	NTC, PTC	NTC, PTC	NTC, PTC	NTC, Pt1000	NTC, Pt1000
Defrost			NTC, Pt1000	NTC, PTC	NTC, PTC	NTC, PTC	NTC, PTC	NTC, Pt1000	NTC, Pt1000
Condenser	NTC, PTC on HOT KEY	NTC, PTC on HOT KEY	NTC, Pt1000	NTC, PTC on HOT KEY	NTC, PTC on HOT KEY	NTC, PTC on HOT KEY	NTC, PTC on HOT KEY	NTC, Pt1000	NTC, Pt1000
Digital inputs									
Alarm, start defrost, doorswitch, pressure switch, energy saving, ON/OFF, probe	config	config	2 x config	config	config	config	config	2 x config	2 x config
Relay outputs									
Compressor	8A, 20A	8A, 20A	8A, 16A	8A, 16A	20A	8A, 16A	16A	8A, 16A	8A, 12A
Fans				8A	8A	8A	16A	8A	12A
Light				8A	5A	5A	16A	5A	5A
AUX						8A	16A	8A	7A
Other									
Hot Key/Prog Tool Kit output	pres	pres	pres	pres	pres	pres	pres	pres	pres
Remote display output	opt	opt	pres	opt	opt	opt	opt	pres	pres
Serial output	TTL	TTL	RS485	TTL	TTL	TTL	TTL	RS485	RS485
Buzzer	opt	opt	opt	opt	opt	opt	opt	opt	opt
Real time clock		opt	opt			opt	opt	opt	opt

XR20CH

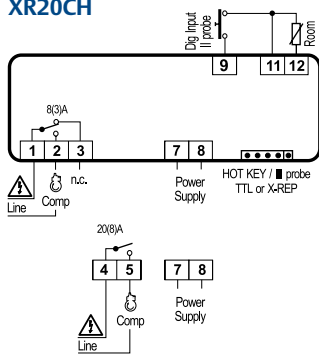

XR30CH

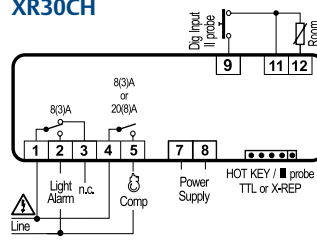

XR35CH

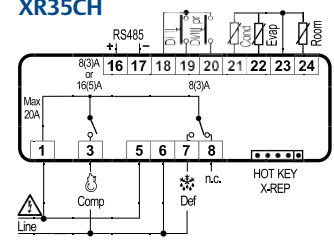

XR60CH

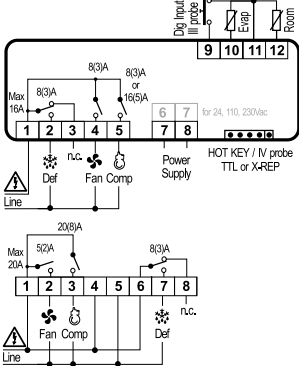

XR70CH

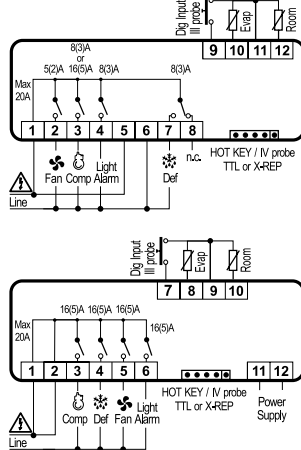

XR75CH

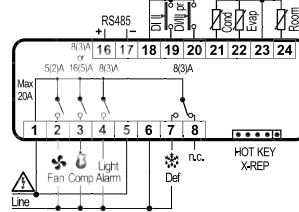

XR77CH

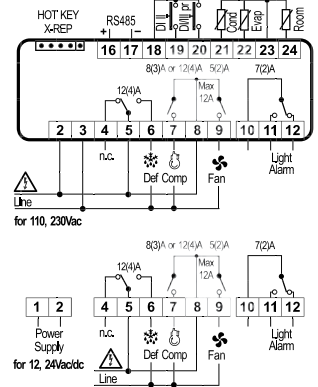

Wing LH Series (compact version)

FEATURES	STATIC APPLICATIONS		VENTILATED APPLICATIONS		
	XW20LH	XW20LRH	XW60LH	XW60LRH	XW90LH
Keyboard: push buttons	6	6	6	6	8
Power supply	110, 230Vac	110, 230Vac	110, 230Vac	110, 230Vac	110, 230Vac
Probe inputs					
Thermostat	NTC, PTC	NTC, PTC	NTC, PTC	NTC, PTC	NTC, PTC
Defrost	NTC, PTC	NTC, PTC	NTC, PTC	NTC, PTC	NTC, PTC
Condenser	NTC, PTC	NTC, PTC	NTC, PTC	NTC, PTC	NTC, PTC
Display	NTC, PTC		NTC, PTC		NTC, PTC
Digital inputs					
Alarm, start defrost, doorswitch, pressure switch, energy saving, ON/OFF	2 x config	2 x config	2 x config	2 x config	2 x config
Relay outputs					
Compressor	20A	20A	20A	20A	20A
Defrost			8A	8A	16A
Fans			8A	5A	8A
Light	8A, 16A	8A	8A, 16A	5A	8A, 16A
Alarm, AUX					8A
RL 6 configurable					8A
Other					
Hot Key/Prog Tool Kit output	pres	pres	pres	pres	pres
Remote display output	opt	opt	opt		opt
Serial output	TTL	TTL	TTL	TTL	TTL
Buzzer	opt	opt	opt	opt	opt
Real time clock	opt	opt	opt	opt	opt

Wing LH (Keyboard)

Also the WING K series (split version) is available in the LH version by using the new T620H keyboard.



Wing LH (back panel with membrane keyboard)

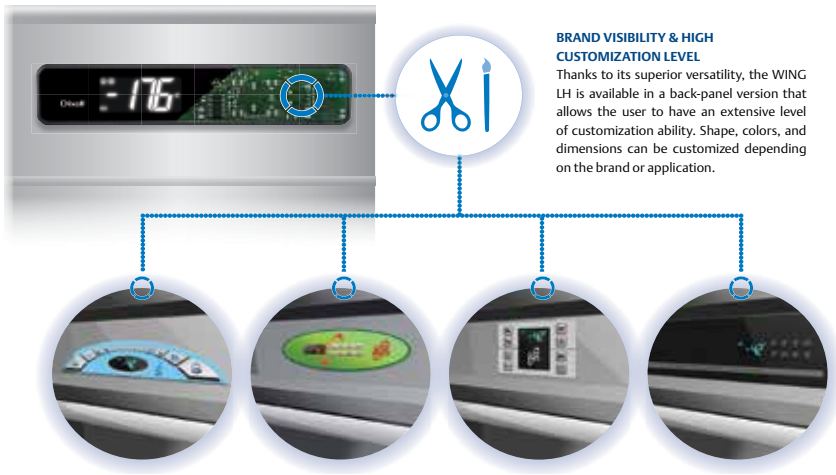

WING LH Back panel Assembly

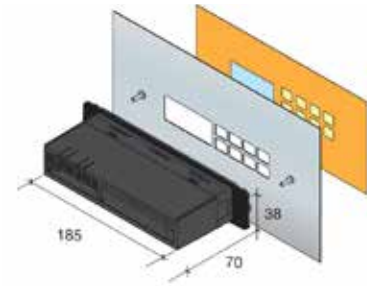

Brand Visibility & High Customization Level

Thanks to its superior versatility, the WING LH is available in a back-panel version that allows the user to have an extensive level of customization ability. Shape, colors, and dimensions can be customized depending on the brand or application.

T620GT: New Glass Touch Keyboard

Dixell presents the innovative keyboard T620GT for Wing Basic controllers in K format for back-glass mounting on refrigerated showcases. This solution allows a high customization level and it's particularly suitable for pastry shops and ice-cream parlor environments.



Compatibility

it's particularly suitable for pastry shops and ice-cream parlor environments.



XW20K | XW40K | XW60K | XW70K

10m



Display

Besides 6 capacitive and backlit keys, T620GT has a wider and elegant display with integrated icons for displaying data and measurement units in real time. The display is available in multiple colors: red (standard), white, or blue.



Dedicated icon for energy saving status information

ECO

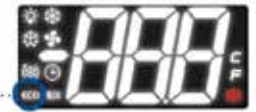

Dimensions

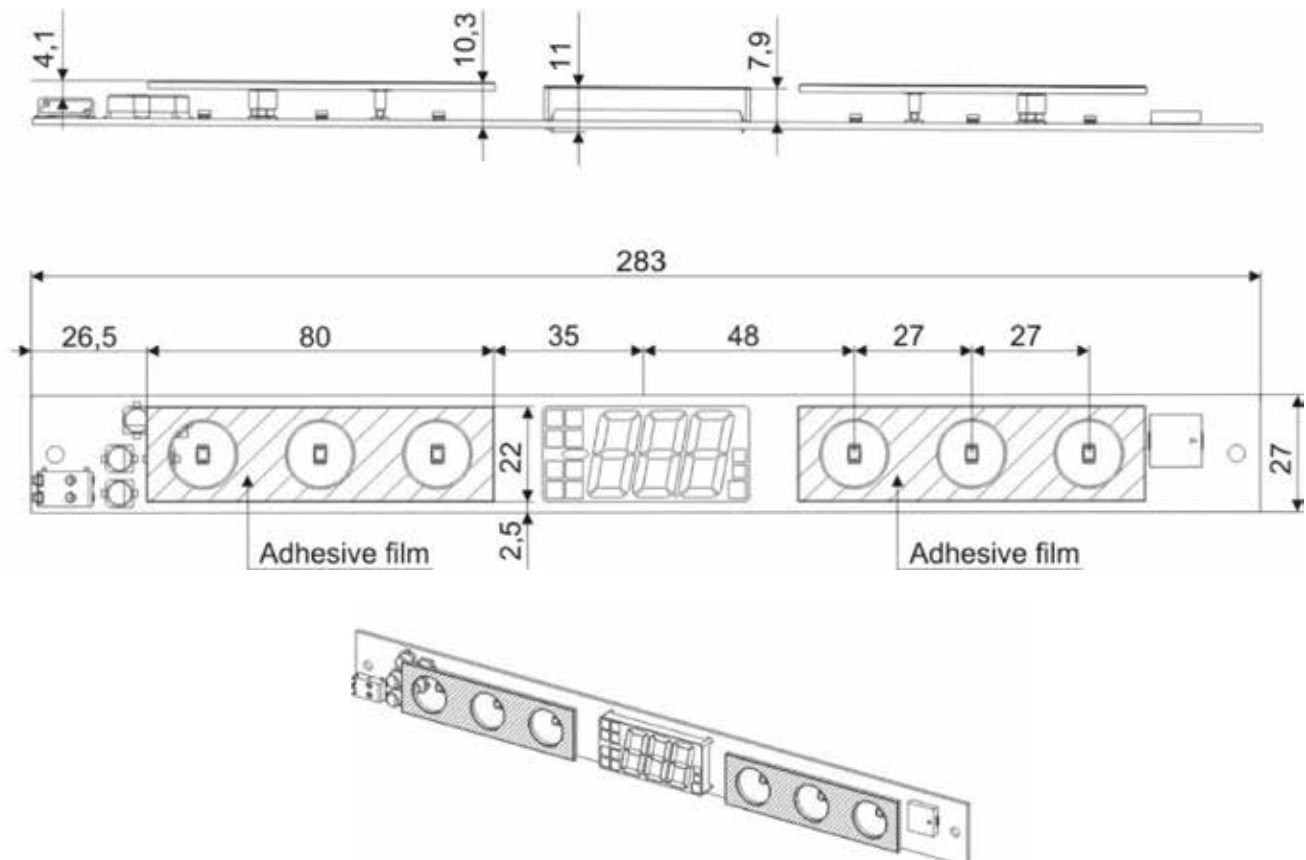

XB590L: Blast Chiller Controller

- Personalized cycles and interface
- Direct access to the Main Functions
- Easy to shift from Soft or Hard blast chilling and quick-freezing
- Automatic transition to the conservation phase
- Device does not require any particular setting
- Cycle can be launched with temperature or time control
- Eight keys quick and easy programming
- Display icons for instant understanding of the process status
- Easy to clean front surface and guarantees an IP65 protection



XB590L new blast chiller controller with customizable user interface for blast chilling and food freezing and conservation, respecting food safety standards. XB590L stands out thanks to the high level of customization of blast chilling cycles and of user interface.

FEATURES

Housing:	Self extinguishing ABS
Format:	185x38mm, depth 76mm with front polycarbonate
Mounting:	Back panel with n°2 screws Ø3x2mm (distance between holes of 165mm)
Front protection level:	IP65 (with polycarbonate)
Protection level:	IP20
Connections:	Screw terminal block for conductors ≤2,5mm ²
	Male faston 6,3mm
Power source:	24, 110, 230Vac, 50-60Hz
Power absorption:	7VA max
Analog inputs:	5 probes NTC o PTC
Digital inputs:	Door and configurable, voltage-free contacts
Relay outputs:	Compressor (SPST 20(8)A, 250Vac) Defrost (SPST 8(3)A, 250Vac) Fan (SPST 8(3)A, 250Vac) Light (SPST 16(6)A, 250Vac) Aux (SPST 8(3)A, 250Vac) Alarm (SPST 16(6)A, 250vac)
Serial outputs (optional):	RS232 for printer Dixell XB07PR
Other:	Connection for Hot Key 128K/Prog Tool Kit Remote display output (optional) Buzzer Internal clock (RTC)

XB590L

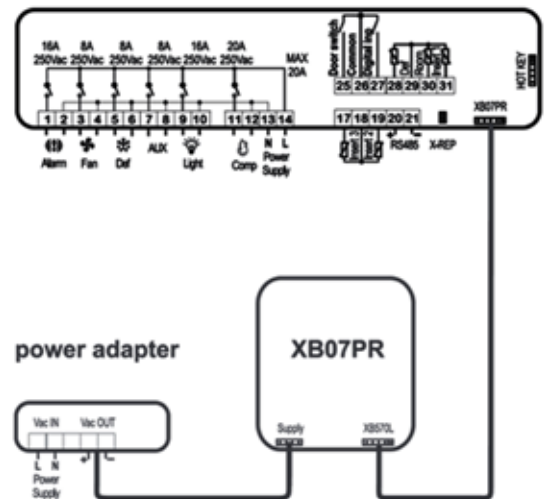

XB887D: Controller for Blast Chillers

XB8870D is the innovative controller for the optimized management of blast chillers. Designed to better manage blast chilling, freezing and food storing, it is characterized by its configurability and easiness of use of the chilling cycles. The highly customizable user interface and the high performances are just some of the features that allow the controller to fully satisfy even the most demanding customers. The strong points of this device are the relays with higher capacity suited to directly drive the loads and the connections with screw disconnectable connectors.

The controller is available in 10 DIN Rail size, and, thanks to Visotouch graphic display, it allows the user to instantly obtain complete information on the status of the machine (room temperature, product temperature, remaining cycle time, etc.).

Chill and Freeze cycles

- **Chill:** when it is necessary to reduce the temperature with immediate impact, below 10°C (from 35°C to 65°C is the critical temperature zone for the higher bacterial proliferation).
- **Freeze:** normally preceded by a CHILL cycle, it is used to freeze food in a faster way in order to preserve its organoleptic properties and to avoid icing inside of it.

Technical Data

Housing	Self extinguishing ABS, white, 10DIN, 175x110x59.5mm (WxHxD)
Mounting	DIN Rail
Connection	Screw disconnectable connectors
Power supply	24Vac
Power absorption	20VA (for applications with unipolar electronic valve: 40VA)
Analog Inputs	5 x NTC, PTC, PT1000 2 x NTC, PTC, PT1000, 4÷20mA, 0÷10V
Digital Inputs	6 x free contact
Digital Outputs	4x 16(8)A, 1x 16A In-Rush (for led lights), 3x 8(5)A
Analog Outputs	1x 0÷10V, 4÷20mA o PWM 2x 0÷10V o 4÷20mA
Other	RS485 Slave USB ETHERNET (by converter USB-ETH-CONV) Connection for remote Touch keyboard Internal Clock



Dimensions

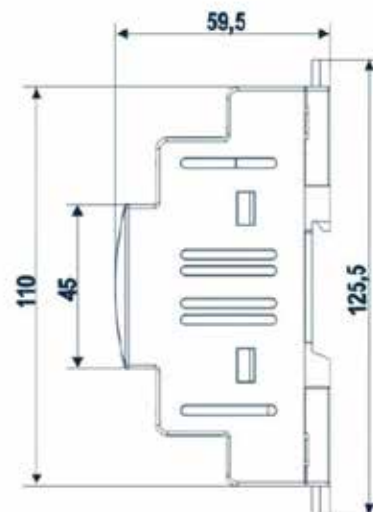
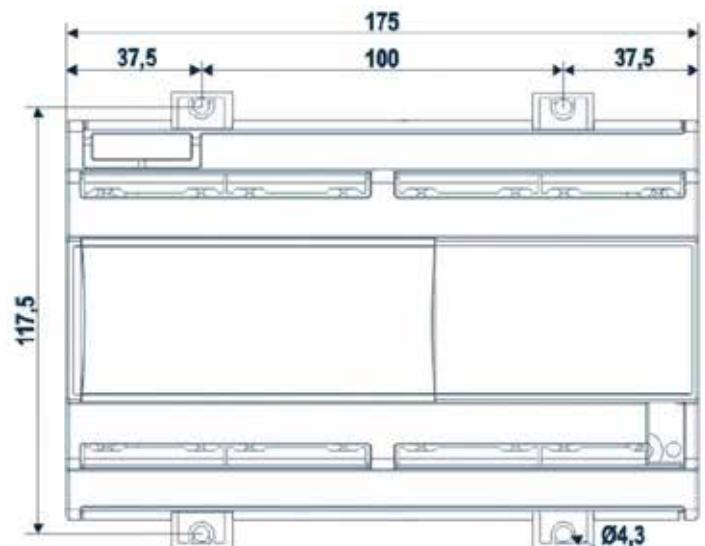

VISOTOUCH: For Blast Chiller Application

Dixell expands its range of products dedicated to blast chillers by introducing a new application designed to manage blast chilling, freezing and food preservation.

The application is available for the iProGENIUS family (4 and 10DIN) and XB800D (10DIN) combined with the VISOTOUCH interface. The personalization of the cycles, each of which can be divided into various phases, and the interface give the possibility to the user to totally customize the application, both in performance and design. The blast chilling (CHILL) and quick-freezing (FREEZE) phases can be Soft or Hard, switching automatically to the preservation phase when necessary; each cycle can be started checking the food temperature or by time.

The application, thanks to the advanced algorithms that characterize it, is able to detect if the needle probe is inserted and, if not, automatically switches to time cycles.

Chill and Freeze cycles

- **Chill:** it is necessary to reduce the temperature with immediate impact, below 10°C, because in the critical temperature zone (from 35°C to 65°C) there is a high bacterial proliferation.
- **Freeze:** normally preceded by a chilling cycle, it is used to freeze in a faster way the food to preserve its organoleptic properties and to avoid icing inside of it.

Functioning

The cycles can be set according to TIME or TEMPERATURE. If the cycle is set by time, its duration will be the selected time (the food temperature is not considered); if the cycle is set by temperature, it will finish once the product (through the needle probe) will reach the selected temperature. In both cases the temperature of the room is controlled by the room probe, which is also used for the compressor control. Cycles can be SOFT or HARD.

- **SOFT CHILL Cycles:** the blast chiller works with a room temperature that usually is positive.
- **HARD CHILL Cycles:** the blast chiller works with different room temperatures; usually the first one is negative while the second one is positive.
- **SOFT FREEZE cycle:** the blast chiller works at different room temperatures. Usually the first is positive (around 0° C), while the second is negative (usually around -35 °C)
- **HARD FREEZE cycle:** the chiller works at a room temperature that is usually around -35 °C.

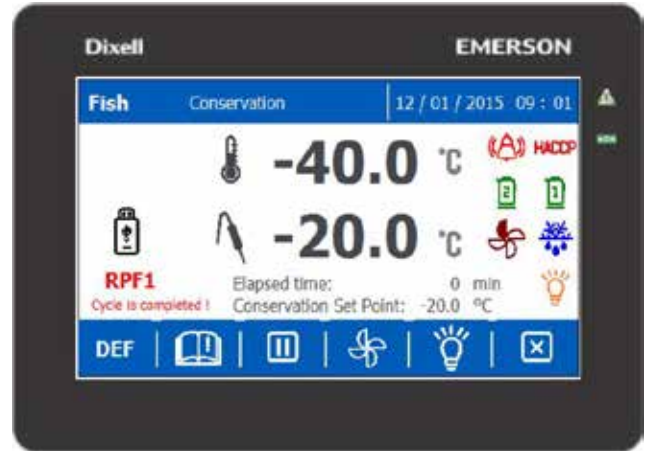

	Chill cycle	Freeze cycle
Initial Product Temperature	90°C	90°C
Final Product Temperature	3°C	-18°C
Cycle Duration	90 min	240 min

Default Blast Chilling Cycle And Freezing Process

The blast chilling (+3°C) and quick-freezing (-18°C) phases can be Soft or Hard. At the end of the cycle, the controller automatically switches to the preservation mode (+2°C for blast chilling, -20°C for quick-freezing).

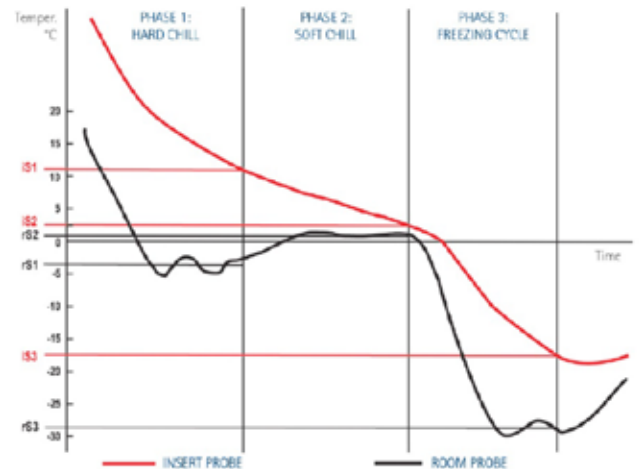

COOLMATE: For Industrial and Commercial Refrigeration

The XLH 200/300 series can simultaneously manage both temperature and humidity. With these controllers, it is possible to program duty and standby cycles or automatic cycles of extraction fans in maturing room applications.

Benefits

- Instant visibility of machine status via display icons
- Clear alarm signals thanks to the front lid
- Hot Key or Prog Tool Kit connector for quick and easy programming
- 10 VA max power absorption

Other Features

- Advanced multifunction controllers with temperature and humidity management
- Cooling and heating action for safe storage of products
- Defrost management
- Possibility of excluding humidity control
- Dehumidifying action by cooling circuit
- Running and stopping programmable cycles with different setpoints (XLH300)
- Automatic cycles of extraction fans (XLH300)
- Direct line power supply 230 (110) VAC
- Designed to be wall or panel mounted
- Standard communication protocol ModBUS-RTU
- TTL output for Hot Key/Prog tool programming
- Direct RS485 serial port (optional)
- Dual display with red LED and yellow LED and 17 icons



Dimensions

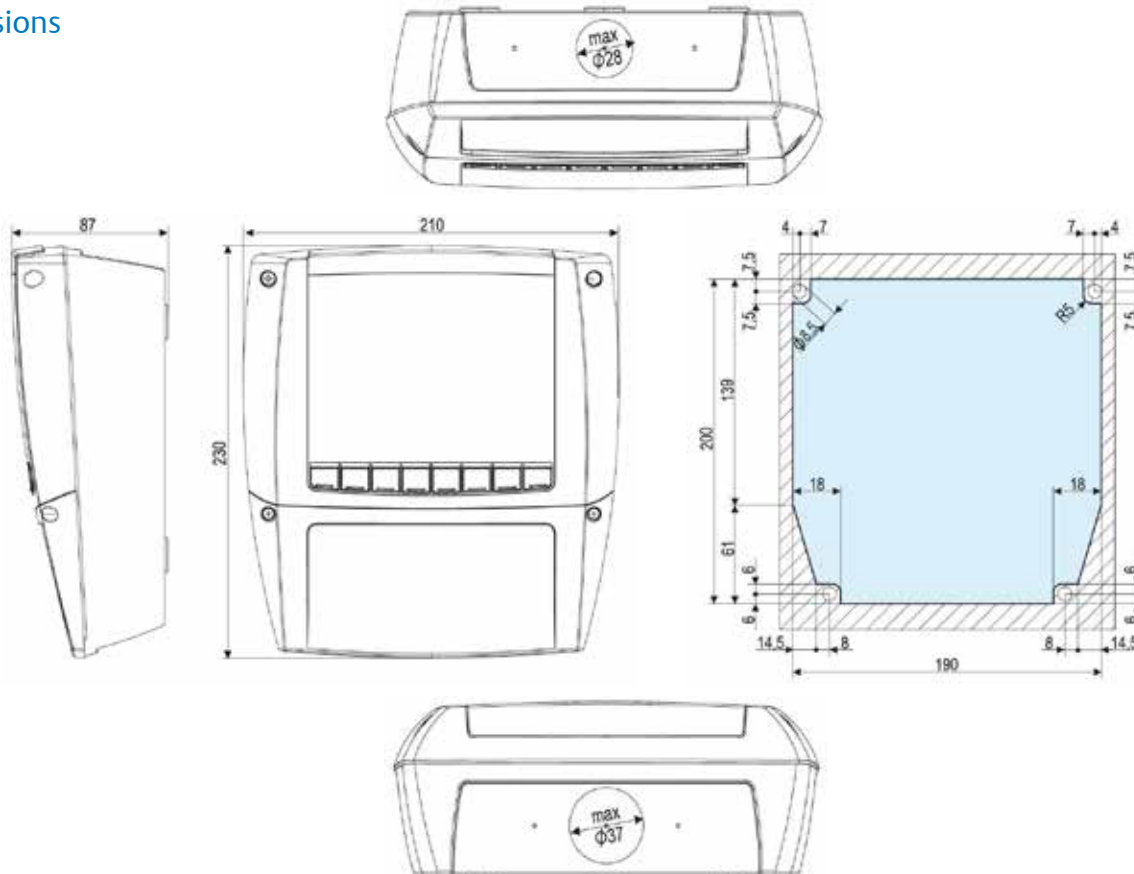

XRi & XWi: Controllers For Plug In Units with Variable Capacity Compressors

XRi and XWi controllers offer the optimum solution for controlling plug-in units with variable capacity compressors. The controllers, available in compact and split versions, maximize energy savings, extend appliance reliability and efficient management of the product maintenance temperature.

An important feature is the reduction of plant handling costs due to reduction in reactive power demand. They are designed for plug in, open islands, cabinet with refrigeration systems, bottle and wine coolers.

- Reduction in reactive power demand
- Extended appliance reliability
- Efficient management of product maintenance temperature
- Low noise and vibrations

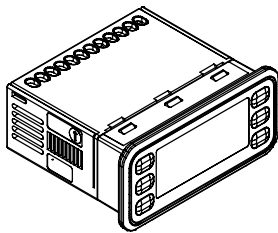

XRi

- Single compressor
- Frequency control for VCC
- Condenser control and alarm monitoring
- Dual control mode for chiller and freeze applications

Applications

- Standard coolers and freezers
- Chest coolers and freezers
- Overhanging freezer cabinets

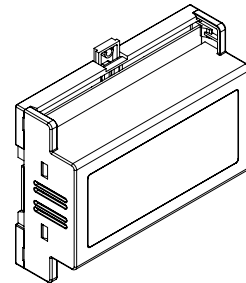

XWi

- Single/double compressor
- Single/multiple variable speed ventilators
- Frequency/serial control for VCC
- Large choice of defrost strategies
- Condenser control and alarm monitoring
- Dual control mode for chiller and freeze applications

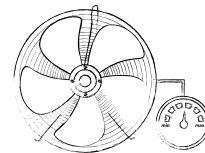
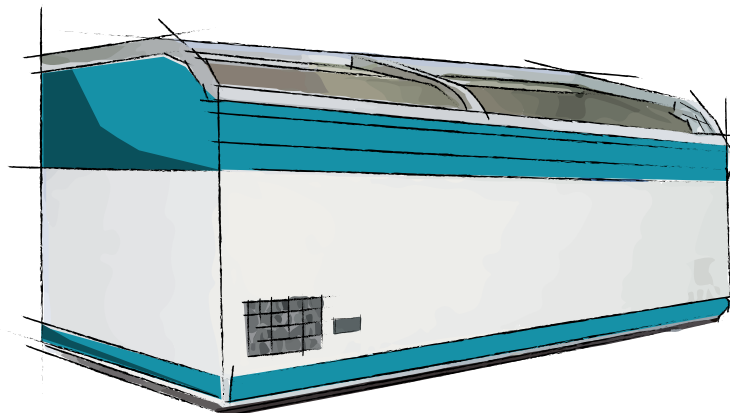

VARIABLE SPEED FAN MANAGEMENT

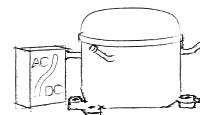

INVERTER COMPRESSOR MANAGEMENT

XW700 Series: Pharmaceutical Controller

- Digital controllers for pharmaceutical cabinets
- Also ideal for applications up to -100°C
- Temperature, alarms and load status recording
- VGW870 LCD graphic interface (or Touch Screen on request) with panel or wall mounting
- Last 24 hours temperature graphic display
- Battery backup in case of power supply failure
- Data download on USB pen drive: txt format compatible with EXCEL®
- Data recording: up to 1 year with sampling every 15 minutes
- Programmable sampling time from 3 to 60 minutes
- Hot Key or Prog Tool Kit connector for quick and easy programming
- Serial connection to monitoring systems

FEATURES	XW737K	XW777K
Display	LCD on VGW870	LCD on VGW870
Power supply	110, 230 Vac	110, 230 Vac
Probe inputs		
Thermostat	NTC, Pt1000	NTC, Pt1000
Defrost	NTC, Pt1000	NTC, Pt1000
Product 1	NTC, Pt1000	NTC, Pt1000
Product 2	NTC, Pt1000	NTC, Pt1000
Digital inputs		
Alarm, start defrost, door switch, pressure switch	2 x config	2 x config
Relay outputs		
Compressor	20A	20A
Defrost		8A
Fans	8A	8A
Light	16A	16A
Alarm	8A	8A
AUX		8A
Other		
Hot Key/Prog Tool Kit output	pres	pres
Visokey output		
USB output	pres	pres
Serial output	TTL	TTL
Buzzer	on keyboard	on keyboard
Real-time clock	with battery	with battery
Backup battery input	pres	pres



K: 8 DIN Rail

VG: 82 x 156mm

XW737K

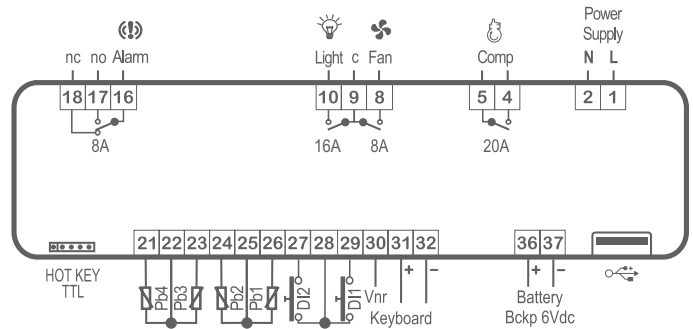

XW777K

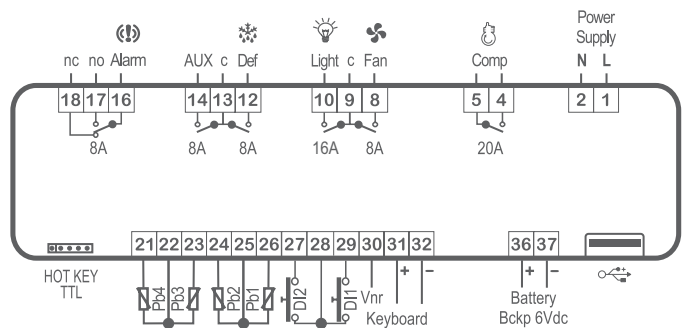

XJM: I/O Management

- Acquisition and command module for refrigeration, air conditioning and BMS applications
- Great flexibility: all the necessary I/O types in one device
- Configurable analog inputs
- Data acquisition by means of sensors with alarm limits
- Up to 12 digital inputs for alarms, status and sensors interlock
- Pressure/temperature conversion
- Available with or without display
- Hot Key or Prog Tool Kit connector for quick and easy programming
- Serial connection to monitoring systems or BMS
- Dual display with red LED (8,5 mm high) and yellow LED (7,5 mm high) and 17 icons



D: 4 DIN Rail

100 x 64 mm

Typical Applications

Retrofit and data acquisition for:

- Cabinets
- Cold rooms with 2 evaporators
- Compressor racks up to 4 compressors
- Pulses counters

FEATURES	XJM60D				VJM60
First display: n° digits	4 d.p.	no display	4 d.p.	no display	4 d.p.
Second display: n° digits	4 d.p.		4 d.p.		4 d.p.
Power supply	24 Vac	24 Vac	110, 230 Vac	110, 230 Vac	from controller
Inputs					
Probe					
Digital (free of voltage)	6 x config*	6 x config*	6 x config*	6 x config*	
Digital (power supply voltage)	6	6	2	2	
Relay outputs					
Configurable	1 x 5A, 4 x 5A opt	1 x 5A, 4 x 5A opt	1 x 5A	1 x 5A	
Other					
Hot Key/Prog Tool Kit	pres	pres	pres	pres	
Remote keyboard		VJM60		VJM60	
Analog output	4÷20 mA/ 0÷10 V	4÷20 mA/ 0÷10 V	4÷20 mA/ 0÷10 V	4÷20 mA/ 0÷10 V	
Serial output	RS485	RS485	RS485	RS485	

* Up to 6 digital inputs or 6 x NTC/PTC/Pt1000 probe inputs or 3 x NTC/PTC/Pt1000 probe inputs + 3 x 4÷20mA/0÷5V/0÷10V/pulse probe inputs

XJM60D

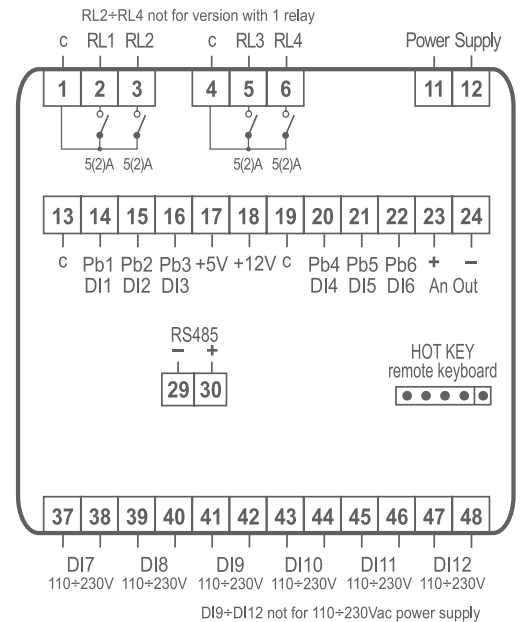



XJM60D with 90 ÷ 260Vac

The XJM60D is the new system family for the optimum management of Retail field and HVAC/R applications. New innovative tools to improve the efficiency of both small and large applications are available such as the advanced graphical one to facilitate the data analysis. Furthermore, systems are provided with a customizable web user interface to make navigation easier and without any additional software. XJM60D is designed to obtain energy savings, thereby reducing running costs and helping to preserve the environment. Our solutions are synonymous with quality, user-friendliness and efficiency because they are focused to meet end user needs.



Hardware Features

	WITH DISPLAY	WITHOUT DISPLAY
First display	4DGT with decimal point	-
Second display	4DGT with decimal point	-
Dimensions	4DIN	4DIN
Keyboard	6 keys	-
Remote keyboard	-	VJM60
Power supply	24Vac o 90 ÷ 260Vac	24Vac o 90 ÷ 260Vac
Analog inputs	Up to 6 probes NTC, PTC, PT1000, 4 ÷ 20mA, 0 ÷ 5V, 0 ÷ 10V	Up to 6 probes NTC, PTC, PT1000, 4 ÷ 20mA, 0 ÷ 5V, 0 ÷ 10V
Digital inputs	Up to 6 free of voltage and 6 power supply voltage contacts	Up to 6 free of voltage and 6 power supply voltage contacts
Relay outputs	3 x 5A with 90 ÷ 260Vac power supply 4 x 5A with 24Vac power supply	3 x 5A with 90 ÷ 260Vac power supply 4 x 5A with 24Vac power supply
Hot key	Present	-
Prog Tool Kit	Present	Present
Analog output	4 ÷ 20mA or 0 ÷ 10V	4 ÷ 20mA or 0 ÷ 10V
Serial output	RS485	RS485
Product shot		

XWEB EVO: Supervisor and Monitoring Systems

The XWEB EVO is the new system family for the optimum management of Retail field and HVAC/R applications. New innovative tools to improve the efficiency of both small and large applications are available such as the advanced graphical one to facilitate the data analysis. Furthermore, systems are provided with a customizable web user interface to make navigation easier and without any additional software. XWEB EVO is designed to obtain energy savings, thereby reducing running costs and helping to preserve the environment. Our solutions are synonymous with quality, user-friendliness and efficiency because they are focused to meet end user needs.

- Alarm Management**
 An effective alarm management system easily detects and signals alarm status so prompt intervention can restore optimum functioning of the application.
- Food Quality**
 Constant data recording, HACCP reports and timely alarm notification guarantee high quality of fresh and frozen food and is in compliance with the UNI EN 12830 rule.
- High Connectivity**
 A powerful hardware platform with USB, Ethernet, RS485 ports, and more, offers the maximum level of connectivity.
- Energy Saving**
 Special algorithms and continuous tracking of energy usage optimizes the application's efficiency by increasing energy savings and reducing costs.



- High Integration**
 The user interface is available for modern Web browsers without the need to install additional software. XWEB EVO is also compatible with HD and touch-screen technologies and tablets.
- Environmentally Friendly**
 With our eco-friendly solutions, innovation an efficiency means respecting the environment by optimizing consumption and reducing pollution, gas emission and waste.

- Hypermarkets
- Supermarkets
- Restaurants
- Convenience Stores
- Petrol Stations

**Alarm Management
and Control**

**Monitoring
and Control**

**Industrial Monitoring
and Control**

**Monitoring, Control, Energy
Optimization and Supervision**

Cold Chain Solution: Compressor Racks and Condensing Unit Applications

Overview / Introduction

The compressor rack controller guarantees an excellent system efficiency by taking into account the actual operative conditions, which is vital in achieving effective energy saving. By use of the dynamic setpoint, the system automatically modifies the suction or condensing temperature/pressure according to the external ambient or the retail space temperature, thus changing the refrigeration power depending on the real thermodynamic exchange. It's also important check heat recovery and an accurate management of the sub-cooling in order to increase system and inverter output efficiency that assure a uniform check of the refrigeration power and its condensation.



XEV02: Digital™ Compressor Applications

- Driver slave for Digital™ compressor management
- Compatible with XC400/600, XC1000 and iProRACK controllers
- Optimal management of “Demand Cooling” applications
- Last 10 alarms recording (kind, duration)
- Temperature analog inputs (NTC86K, Pt1000)
- Pressure analog inputs (0÷5 V, 4÷20 mA)
- Alarm management (visual or through digital output)
- Digital inputs (1 insulated, 1 voltage)
- Hot Key or Prog Tool Kit connector for quick and easy programming
- Serial connection to monitoring systems
- Display with red LED (10,5 mm high) and icons



FEATURES	XEV02D
Display: n° digits	± 3 d.p.
Keyboard: push buttons	4
Power supply	24, 110, 230 Vac
Probe inputs	
Suction pressure	4÷20 mA, 0÷5 V
Discharge line temperature (DLT)	NTC86K, Pt1000
Digital inputs	
Free of voltage	pres
High voltage	pres
Relay outputs	
Alarm	8A config
Other	
Triac output	pres
Open collector output	config
Hot Key/Prog Tool Kit output	pres
Serial output	RS485
Buzzer	opt

XEV02D

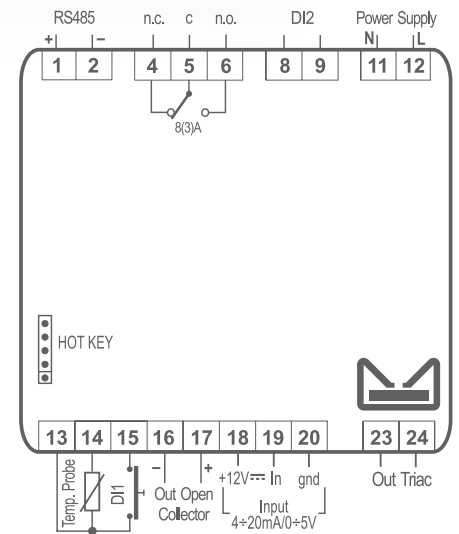

XC15/35 CX Series: Single And Tandem Condensing Units Applications

- Designed for ON/OFF, variable speed and digital compressors
- Advanced condenser fan control (internal triac up to 2A - external driver up to 60A)
- Direct on-board control for electronic fans
- Energy consumption optimization through the load request modulation
- Advanced energy saving features thanks to optimized management both for compressors and fans
- Real time condensing unit monitoring



XC15CX

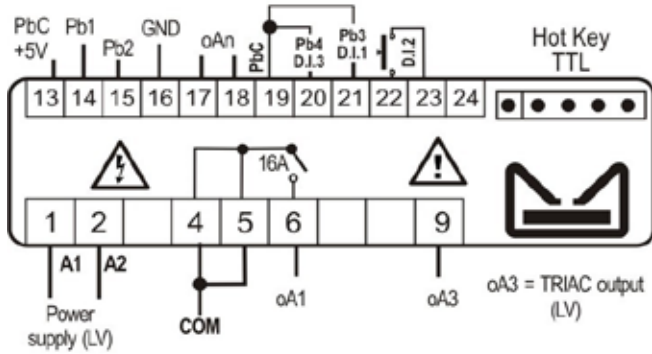

Power supply 110, 230Vac

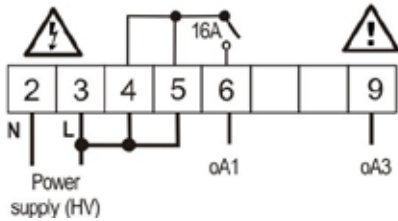

XC35CX

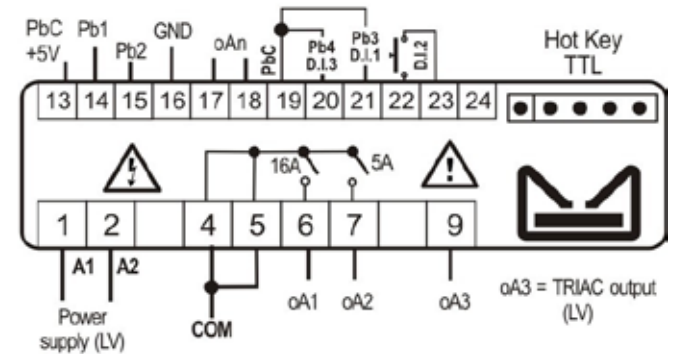

Power supply 110, 230Vac

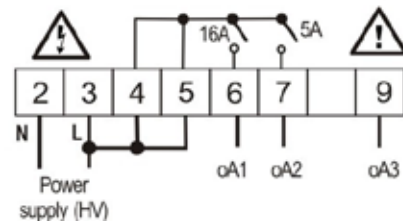

FEATURES	XC15CX	XC35CX
Power supply	24, 110, 230Vac	24, 110, 230Vac
Display	red with icons	red with icons
Keyboard	6 buttons	6 buttons
Probe inputs		
Suction pressure	0÷5V/NTC config	0÷5 V
Condensing pressure	0÷5V/NTC config	0÷5 V, NTC
Discharge temperature	2 x NTC/PTC/ PT100/NTC86K	2 x NTC/PTC/ PT100/NTC86K
Digital inputs		
Configurable	up to 3	up to 3
Power Outputs		
Configurable relay 1	16A	20A
Configurable relay 2		8A
Triac	500W	500W
Other		
Hot Key/Prog Tool Kit/TTL Output	pres	pres
0÷10V/PWM Output	opt	opt
Buzzer	opt	opt
Real time clock	pres	pres

XC400/600 Series: Up to 6 Compressor/ Fan Output Applications also with Inverter Management

- Electronic controllers for compact compressor racks management also with inverter
- Compressor types: Digital™, multi-stages, differing power, semi-hermetic, scroll and screw
- Proportional band or neutral zone control
- Floating condensing pressure control depending on the external temperature
- High configurability and flexibility
- Automatic switch-off of the compressors in case of high condensing pressure/temperature
- Silent mode function for fans during the night
- Correct lubrication automatic restore cycle
- Safer control with low pressure electronic pressure switch
- Type of gas setting: to control temperature or pressure
- Hot Key or Prog Tool Kit connector for quick and easy programming
- Serial connection to monitoring systems
- Dual display with red LED (8,5 mm high) and yellow LED (7,5 mm high) and 17 icons



Type Of Compressor Racks

The XC400/600 series, thanks to a powerful and complete range, ensures optimal management of compact compressor racks:

- with compressors and fans also with suction or discharge inverter
- with 2 discharge and 1 suction also with inverter
- with Digital™ compressors

Example of circuits managed by the XC400/600 series

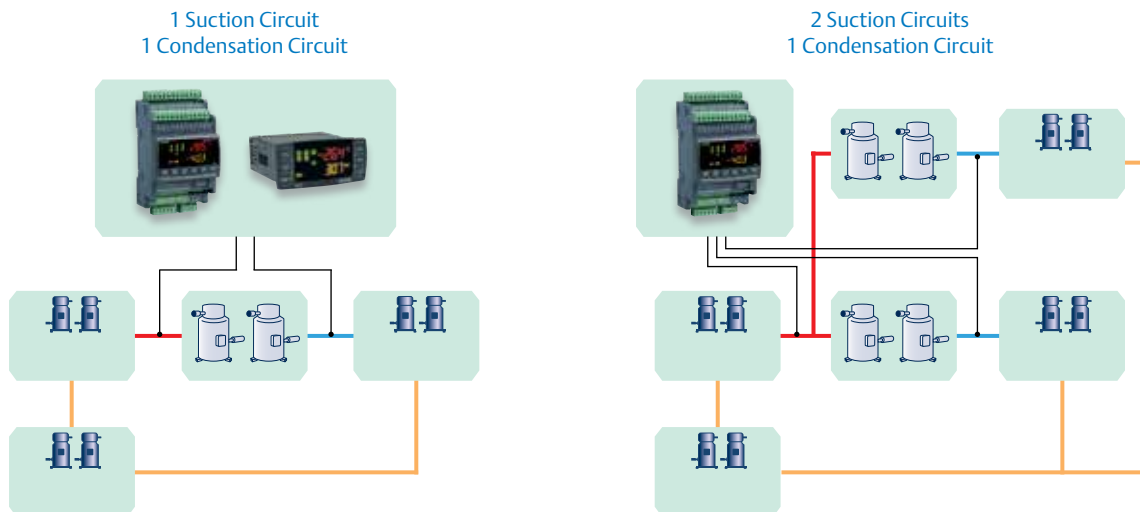



XC450CX	Digital controller for managing up to 5 compressors or fans
XC640D	Digital controller for simultaneous management of up to 4 compressors and fans
XC645CX XC645D	Digital controllers for Digital™ compressor management

FEATURES	XC450CX	XC640D	XC645CX	XC645D
First display: n° digits Second display: n° digits Power supply	± 4 d.p. ± 4 d.p. 12, 24 Vac/dc	± 4 d.p. ± 4 d.p. 110, 230 Vac	± 4 d.p. ± 4 d.p. 12, 24 Vac/dc	± 4 d.p. ± 4 d.p. 110, 230 Vac
Probe inputs				
Suction	0÷5V, 4÷20 mA, NTC	0÷5V, 4÷20 mA, NTC	0÷5V, 4÷20 mA, NTC	0÷5V, 4÷20 mA, NTC
Suction 2				
Condensing	0÷5V, 4÷20 mA, NTC	0÷5V, 4÷20 mA, NTC	0÷5V, 4÷20 mA, NTC	0÷5V, 4÷20 mA, NTC
Configurable		NTC	NTC	NTC
Digital inputs				
Low pressure switch		1	1	1
High pressure switch		1	1	1
Alarm	5	4	4	5
Configurables	1	2	1	2
Relay outputs				
Loads	5 x 5A	4 x 5A	4 x 5A	4 x 5A
Other outputs				
Digital compressor			TRIAC	TRIAC
Inverter-compressor		4÷20 mA/0÷10 V opt		4÷20 mA/0÷10 V opt
Inverter-fans		4÷20 mA/0÷10 V opt		4÷20 mA/0÷10 V opt
Load			4÷20 mA/0÷10 V opt	4÷20 mA/0÷10 V opt
Hot Key/Prog Tool Kit	pres	pres	pres	pres
Serial	TTL	RS485	TTL	RS485
Other				
Remote keyboard		VC660		VC660
Alarms	last 10	last 10	last 10	last 10
Buzzer	opt	pres	opt	pres
Connection kit			CWC15-KIT, CWC30-KIT, CAB/CJ15, CAB/CJ30	

XC450CX

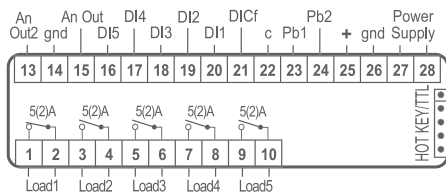

XC645CX

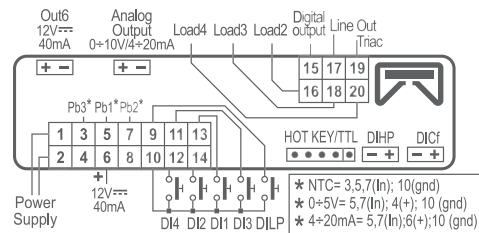

XC640D

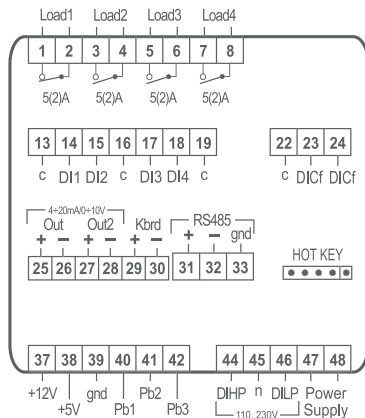

XC645D

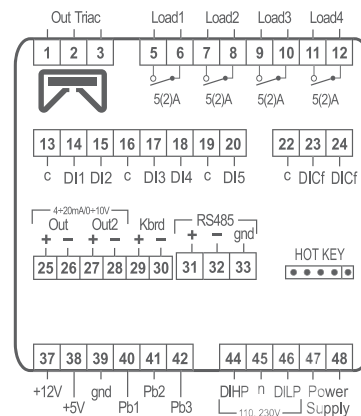



XC650CX	Digital controller for simultaneous management of up to 5 compressors and fans
XC660D	Digital controller for simultaneous management of up to 6 compressors and fans
VC660	Keyboard for XC660D controllers

FEATURES	XC650CX	XC660D	VC660
First display: n° digits	± 4 d.p.	± 4 d.p.	± 4 d.p.
Second display: n° digits	± 4 d.p.	± 4 d.p.	± 4 d.p.
Power supply	12, 24 Vac/dc	110, 230 Vac	from controller
Probe inputs			
Suction	0÷5V, 4÷20 mA, NTC	0÷5V, 4÷20 mA, NTC	
Suction 2			
Condensing	0÷5V, 4÷20 mA, NTC	0÷5V, 4÷20 mA, NTC	
Configurable	NTC	0÷5V, 4÷20 mA, NTC	
Digital inputs			
Low pressure switch	1	1	
High pressure switch	1	1	
Alarm	4	6	
Configurables	1	2	
Relay outputs			
Loads	5 x 5A	6 x 5A	
Other outputs			
Digital compressor			
Inverter-compressor	4÷20 mA/0÷10 V opt	4÷20 mA/0÷10 V opt	
Inverter-fans	4÷20 mA/0÷10 V opt	4÷20 mA/0÷10 V opt	
Load	12V/40 mA		
Hot Key/Prog Tool Kit	pres	pres	
Serial	TTL	RS485	
Other			
Remote keyboard		VC660	
Alarms	last 10	last 10	
Buzzer	opt	pres	opt
Connection kit	CW15-KIT, CW25-KIT, CAB/CJ15, CAB/CJ30		

XC650CX

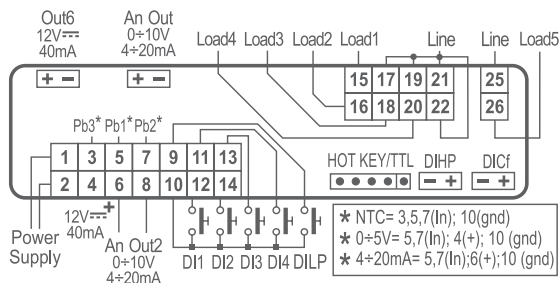

XC660D

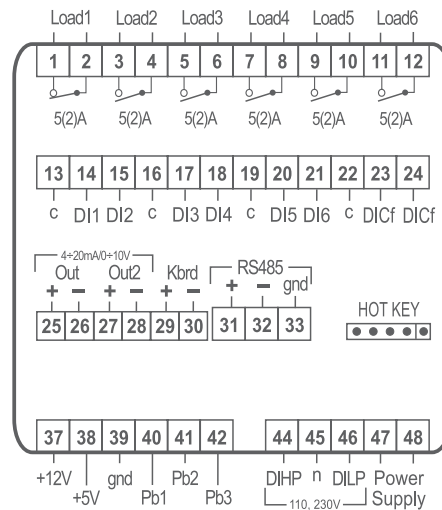

IProRack Series: Up to 6 Compressor/Fan Output Applications also with Inverter Management

- Electronic controllers for compressor racks studied to manage even the most complex installations
- Management of scroll, semi-hermetic, multi-stages, different capacity and screw compressors
- Management of 2 circuits with 2 inverters
- Transcritical CO₂ regulation
- Special algorithms for energy saving
- Suction and condensing dynamic setpoint optimization
- Sub-cooling management
- Copeland™ Stream CoreSense™ diagnostics control module integration
- Concise information about the variables of the compressor rack through the VISOGRAPH
- Powerful platform with LINUX operating system on CPU ARM9 (200MHz/32bit)
- Ethernet for the connection to an intranet-internet network
- USB output for configuration update
- RS485 slave serial outputs for the connection to XWEB EVO supervising and controlling systems
- Type of refrigerants: R22, R134A, R404A, R507, R717, R407, R407C, R407F

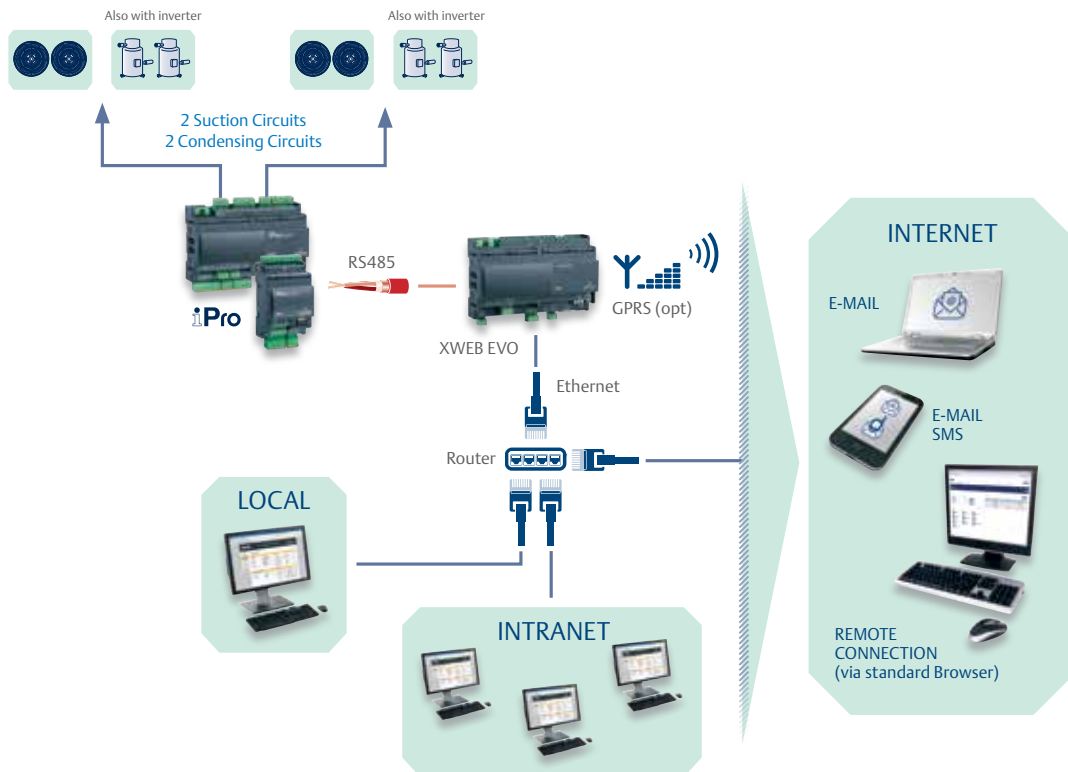

Internal Web Server

The iProRACK controllers have an integrated website that can be easily reached through a standard browser. This instrument is very useful to configure the controller and to display and change the machine variables.

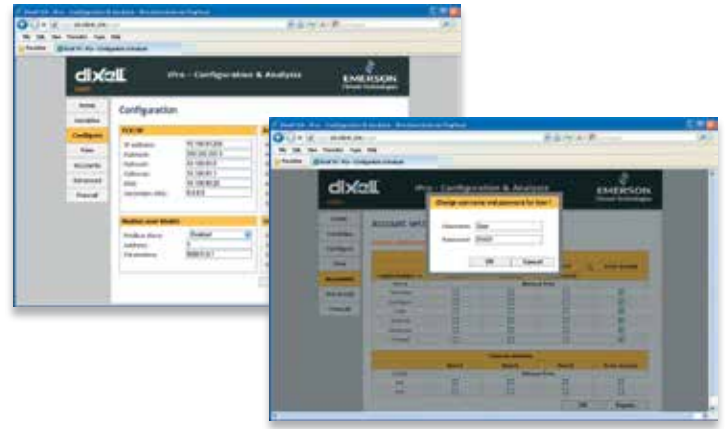

FEATURES	IPR208D	IPR215D	VGIPR
Display	LCD on VGIPG	LCD on VGIPG	LCD - 240x96 pixels from controller
Power supply	24 Vac/dc from TF40D	24 Vac/dc from TF20D	
Probe inputs			
0÷1V, 0÷5V, 0÷10V, 0÷20mA, 4÷20mA, NTC, PTC, DI	6 x config	10 x config	
Digital inputs			
Opto-insulated	11 x config	20 x config	
Relay outputs			
Configurable	8 x 5A	15 x 5A	
Other outputs			
0÷10V/4÷20mA 0÷10V RS485 USB CANBus Ethernet Visokey	4 x config master + slave pres via USB-ETH-CONV	2 x config 4 master + slave pres pres opt	 pres
Other			
Remote display Real-time clock Flash memory Connections Connection kit BACnet protocol Buzzer	1 x VGIPR pres 32 MB bayonet + screw IP-FC208 opt	2 x VGIPR pres 128 MB bayonet + screw IP-FC215CP opt	 opt

IPR208D

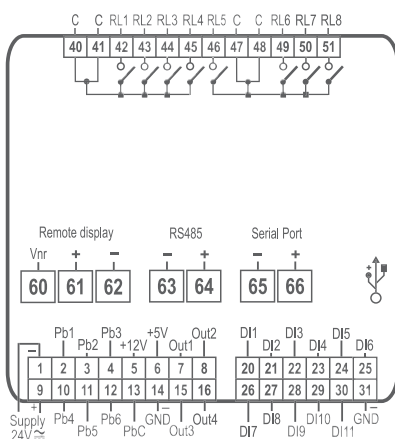

IPR215D

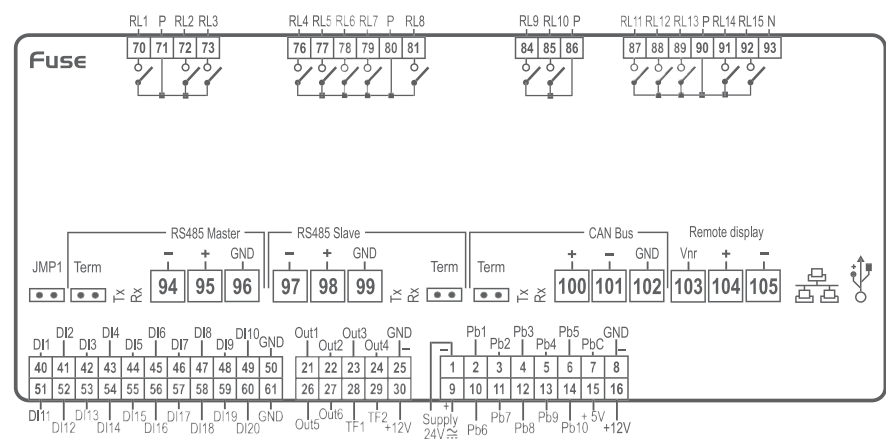

XC1000D: Controllers for Medium and Big Compressor Racks up to 15 Compressor/Fan Output Applications

- Compressors and condensing fans monitoring and management of medium-large compressor racks
- 2 analogue outputs for frequency compressors and 2 analogue outputs for inverter for fans
- Great versatility and extensive customization opportunities
- Reduced and dynamic set point for energy saving management
- Proportional band or dead band control
- Standard communication protocol ModBUS-RTU
- Subcritical CO₂ regulation
- Compressor unloading in case of high condensing pressure alarm
- Suction superheat calculation with alarm management and possible stop of compressors
- Valve management based on superheating value
- Alarm management with absolute and relative pressure
- Electronic pressure-switch management



Kinds of Circuits

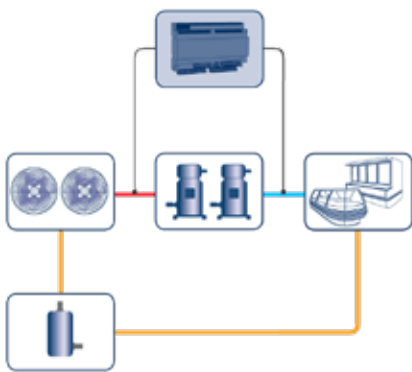

1 suction circuit
1 condensation circuit

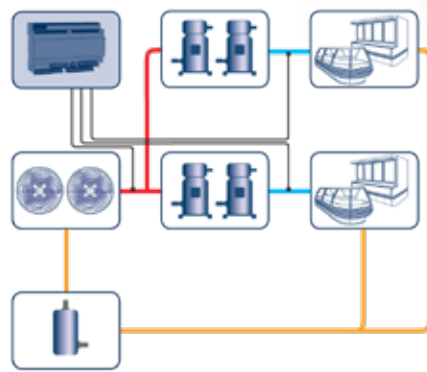

2 suction circuits
1 condensation circuit

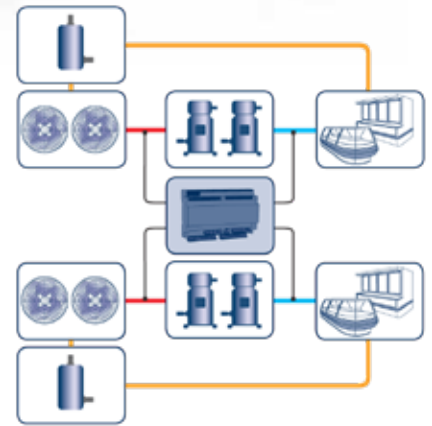

2 suction circuits
2 condensation circuits

Compatibility with Digital™ Compressors

Thanks to its powerful hardware platform and to the advanced algorithms, the XC1000D family is able to drive the majority of compressor racks present in the market. An interesting match is the one with Dixell XEV02D driver that allows management of compressor racks equipped with Digital™ compressors. In these applications, by using the modulating capacity, the plant receives the optimum refrigeration power thereby reducing consumption.



ACC: Control Link for ACC (Anti-Condensate Controller) System

Control Link for ACC (Anti-Condensate Controller) System is a controller for anti-sweat heaters inside glass door cases and can be used either as a stand-alone device or networked with an XWEB EVO monitoring system on ModBUS network.



Control Link for ACC changes the anti-sweat heaters based on the temperature of the door frame and on dew point, providing the most efficient control in order to maximize energy saving.

Features

- Small size: 22x4,3x3cm
- Current Capacity - up to 30A MAX
- 120-250Vac 50/60Hz input power
- Closed Loop Control Algorithm
- RoHS Compliant
- Zero Crossing Switching
- Quick Connection Terminals
- Network Connections

Technical Data

Temperature Range	Storage Temperature: -40°C to 65°C (-40°F to 149°F)
Ambient Operating Temperatures (UL Listed) P/N 815-6100	-40°C to +40°C (-40°F to 104°F) up to 10A (indoor, freestanding with no additional heat sink)
	-40°C to +65°C (-40°F to 149°F) up to 7A (indoor, freestanding with no additional heat sink)
Ambient Operating Temperatures (UL Recognized) P/N 815-6105	-40°C to +25°C (-40°F to 77°F) up to 30A (with additional heat sink with max thermal resistance of 0.51°C/Watt (0.92°F/Watt) -40°C to +40°C (-40°F to 104°F) up to 26A (with additional heat sink with max thermal resistance of 0.51°C/Watt (0.92°F/Watt) -40°C to +65°C (-40°F to 149°F) up to 18A (with additional heat sink with max thermal resistance of 0.51°C/Watt (0.92°F/Watt)
Input Voltage	120/240 Nominal (102VAC to 264VAC) 50/60 Hz
Humidity	5% to 95% non-condensing
Door Frame Temp Sensor	+/- 0.4°C of 0 to 80°C (+/- .72°F of 32°F to 176°F) up to +/- 0.6°C at -40°C and 120°C (+/- 1.08°F at -40°F and 248°F)
Dewpoint Sensor	+/- 1°C (+/- 1.8°F) over RH of 40 to 95% RH +/- 4°C (+/- 7.2°F) over RH of 10 to 40% RH
Agency Approvals	UL916 Open Energy Management Equipment, File E118489, FCC Part 15 Class A (non-intentional radiators), CE, RoHS

Dimension

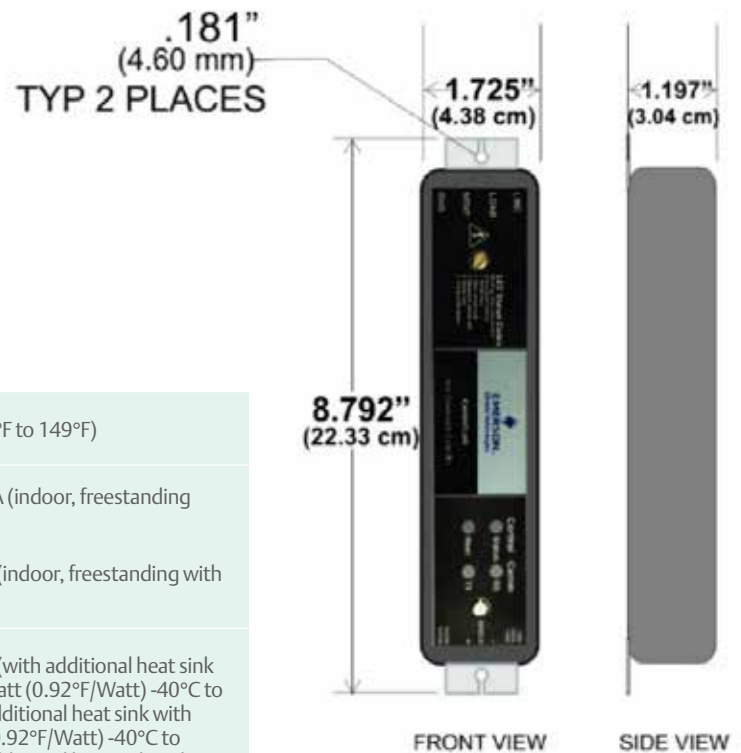

GDS/GDI: Gas Leak Detectors

Benefits:

- Health safety
- Food safety and waste reduction
- Reduced gas taxation
- Improve COP by gas leaks reduction
- Maintenance Cost reduction
- Wide range of gases
- Modbus option



Laws compliance:

- F-GAS
- UNI-EN378
- EU517 / 2014

Features:

- HFC/HFO; Semi conductor
- CO₂; Infrared

Main Applications

- Supermarket, Food storage, Food distribution centers
- Large HVAC installations

Stand Alone



with XLH210



Monitored by XWEB EVO



Cold Chain Solution: Programmable Controllers

Overview / Introduction

iPro family, dedicated whether for HVAC/R units, is characterized by the most advanced technology in connectivity and processing speed. It is based on a powerful platform that includes one hardware configuration that is able to expand the actual solution in the market, and a software that, thanks to the ISaGRAF® development environment, allows the development through standard programming languages.

An easy and useful HMI is also guaranteed through the VISOGRAPH graphic display, as the expandability and the solution to many applications are satisfied with a complete range of accessories, among which, I/O expansion modules and proportional electronic valve management, modem and wiring.



iProGenius

iProGenius is the Dixell family of programmable controllers that offers optimal solutions for all HVAC/R needs. They are suited for all applications in the PLC world including shopping centers, hospitals, airports, boatyards, energy management plants, and more. These controllers provide a high level of technology for ease of external connectivity and programmability providing simple answers for the user's needs, while offering local or remote monitoring control (accomplished with the powerful iProLINK connectivity module). An intuitive and useful HMI is also offered through the VISOGRAPH graphic display and the touch screen TGIPG display, while the expandability provided by the IPX modules allows use of these controllers with any machine, including the most complex.

Features:

- Powerful platform based on LINUX operative system on ARM9 (200MHz/32bit) microprocessor
- Internal Web Server with standard or customized Web Site
- Ethernet for connection to an intranet-internet network and to other controllers for a distributed application management
- USB output that allows the download of parameters, data/alarm logger and the applications and parameters upload
- Slave RS485 serial outputs for the connection to XWEB EVO supervising and controlling systems or to applications developed by third party systems
- BACnet communications allows the system to have easy and immediate integration with different manufactures ensuring complete interoperability
- Connection to the driver for the management and control of electronic expansion valves



IPG808D: Programmable Controller For Compact Solutions

Dixell introduces the new controller for HVAC/R applications with integrated power relays and valve driver.

IPG808D is the innovative controller developed to manage in an optimized way small units like refrigerated cabinets, chillers and more, without the use of extra hardware such as contactors or valve drivers. The highly customizable user interface and the high performances are just some of the features that allow the controller to fully satisfy even the most demanding customers.

The strong points of this device are the relays with higher capacity suited to directly drive the loads and the connections with screw disconnectable connectors.

The controller is available in 10 DIN Rail size, and, thanks to the VISOTOUCH touch screen graphic display, it allows the user to customize even the information screens regarding the unit status.

Hardware Configurations

Housing	Self extinguishing ABS, white, 10DIN, 175x110x59.5mm (WxHxD)
Mounting	DIN Rail
Connection	Screw disconnectable connectors
Power supply	24Vac
Power absorption	20VA (for applications with unipolar electronic valve: 40VA)
Analog Inputs	5 x NTC, PTC, PT1000 2 x NTC, PTC, PT1000, 4÷20mA, 0÷10V
Digital Inputs	6 x free contact
Digital Outputs	4x16(8)A, 1x16A In-Rush, 3x8(5)A
Analog Outputs	1x 0÷10V, 4÷20mA o PWM 2x 0÷10V o 4÷20mA
Other	RS485 Slave RS485 Master/LAN USB ETHERNET (by converter USB-ETH-CONV) Connection for remote keyboard Internal clock



Dimensions

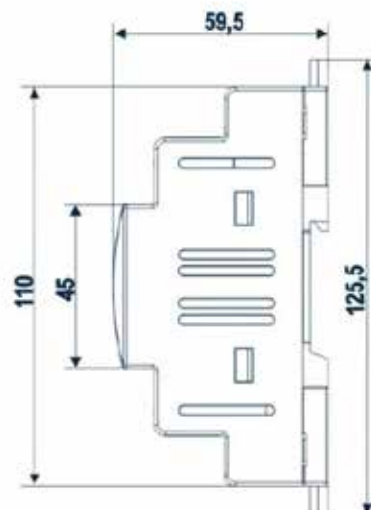
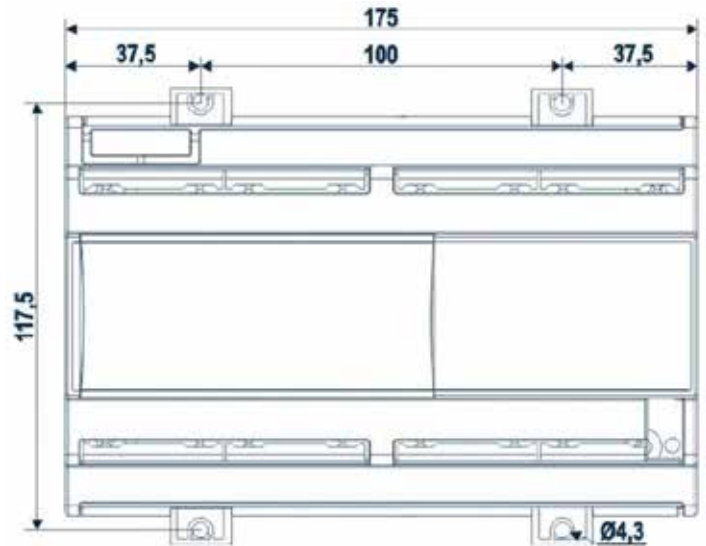

Human Machine Interface:

VISOGRAPH 2.0

Visograph 2.0, the evolution of Visograph LCD interface, maintains the same features, but with a new look and the possibility to use the on-board probes for temperature and humidity control.

Features

- Temperature/humidity probe on board
- Alarms and power supply LEDs
- Membrane keyboard
- Quick panel or wall installation
- Quick programming by hot key

The Visograph 2.0 graphical keyboards are characterized by a new design and a keyboard membrane and represent the ideal solution for interfacing with compatible Dixell controllers; they provide detailed information on the status of the machine via an intuitive and complete interface. The keyboards, for panel or wall mounting, are available in black and white, with flat or chamfered frame.

Visograph 2.0 keyboards are available with dedicated software for Chillers and Compressor racks, also with CO₂. Visograph 2.0 is also available for iProGENIUS programmable controllers; in this case the software needs to be customized by the user. The white keyboard, in combination with the on-board probe for temperature/humidity management, makes it the ideal solution for residential environments.

Technical Data

Power supply	By the controller
Housing	Self extinguishing ABS
Display	240x96pixels, monochromatic LCD display
LED	Red (alarm), green (power on)
Keyboard	Membrane keyboard / 8 keys
Dimensions	Front 95x148mm; 25mm depth for panel mounting and 25,5mm for wall mounting
Mounting	Panel mounting on 89x127mm hole or wall (same drilling template of Visograph 1.0)

Dimensions

Panel Mounting

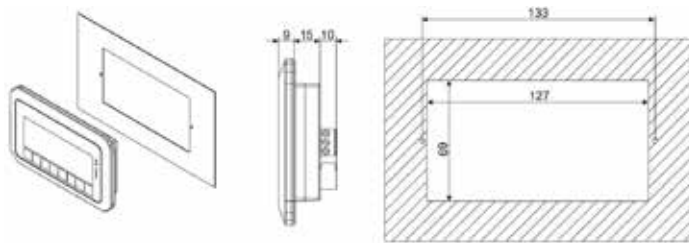

Wall Mounting

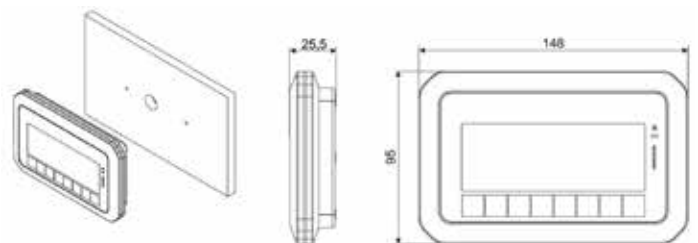

Front protection	Panel mounting: model without on-board probes: IP54 model with on-board probes: IP30 Wall mounting: IP30
Probes (optional)	Temperature probe (on board) Humidity probe (on board) Output for external temperature probe
Outputs/Inputs	VISOKEY
Buzzer	Optional
Connections	Screw connector, max. 2.5mm ²
Operating temperature	-10÷60°C (14÷140°F)
Storage temperature	-30÷70°C (-22÷158°F)
Relative humidity	20÷85% (non condensing)

Human Machine Interface:

VISOTOUCH: Programmable Touch Screen Displays

VISOTOUCH programmable touch screen display features a wide 4.3" and ensures a high performing hardware and full compatibility with IC200 evo, iPro and the possibility of panel or wall mounting, make it extremely versatile and suitable for residential environments or as a IPM500D Dixell controllers. The elegant design, the compact and solid structure machine terminal. Available in horizontal and vertical versions, with or without built-in probes, it is particularly appreciated for its high degree of connectivity, for its touch technology and for its bright display.



Features:

- Built-in probe for temperature and humidity control
- Frontal red LED (alarms) and green LED (ON status)
- High connectivity degree via LAN, RS485 (with ModBUS protocol) and USB port
- Graphic display TFT
- High programmability thanks to the new VISOPROG 5 software
- Versatility in mounting (panel or wall) and in the format (horizontal or vertical)
- Maximum distance from the controller: 100m
- Possibility to connect an additional external temperature probe



FEATURES	VTIC20	VTIPC	VTIPG	VTIPM
Power supply	12, 24Vac/dc	12, 24Vac/dc	12, 24Vac/dc	12, 24Vac/dc
Internal and external probe, digital input	opt	opt	opt	opt
LAN output	pres	pres	pres	pres
RS485 output	opt	opt	opt	opt
Buzzer	pres	pres	pres	pres

Technical Data

Housing	self-extinguishing ABS	Power absorption	5W - 5VA
Touch screen	resistive	Operating temperature	-20÷60°C (-4÷140°F)
Format	4:3 frontal 93x134mm; depth 23,6mm for panel mounting and 30,6mm for wall mounting	Storage temperature	-25÷70°C (-13÷158°F)
Display	480x272pixels TFT, 256 colors	Measuring and regulation range	internal temperature probe: -10÷50°C (14÷122°F) internal humidity probe: 20÷85% external temperature probe: -50÷110°C (-58÷230°F)
Mounting	panel mounting in a 84,5x125mm cut-out or wall mounting	Relative humidity	20÷85% (non condensing)
Front protection	panel: model without built-in probes: IP54 model with built-in probes: IP30 wall: IP20	Resolution	0,1°C or 1°F or 1RH%
Connections	panel version: STELVIO 90° screw connectors wall version - wires section: min 0,5mm ² - max 2,5mm ²	Accuracy (at ambient temperature)	temperature: ±1% humidity: ±3% (20÷80%) / ±5% (elsewhere)
Power supply	12, 24Vac/dc ±15%		

iPro Transcritical CO₂ Booster

The iPro Transcritical CO₂ application controls the operation of the high pressure valve and bypass valve in a Booster Transcritical CO₂ system. The high pressure valve (HPV) will operate in two normal-control modes, in subcritical and transcritical mode. The mode is defined by outside air temperature. In the subcritical mode, the valve will modulate to maintain a subcool setpoint using pressure and temperature control values being read from the outlet of the gas cooler to calculate subcool. In transcritical mode, the high pressure valve starts modulating to maintain a setpoint defined by an efficiency table and using only the pressure input to control. The bypass valve (BV) only operates in one normal-control mode, which is to modulate the valve accordingly to maintain a pressure setpoint. The control reading is from the liquid receiver.



Transcritical CO₂ Booster System

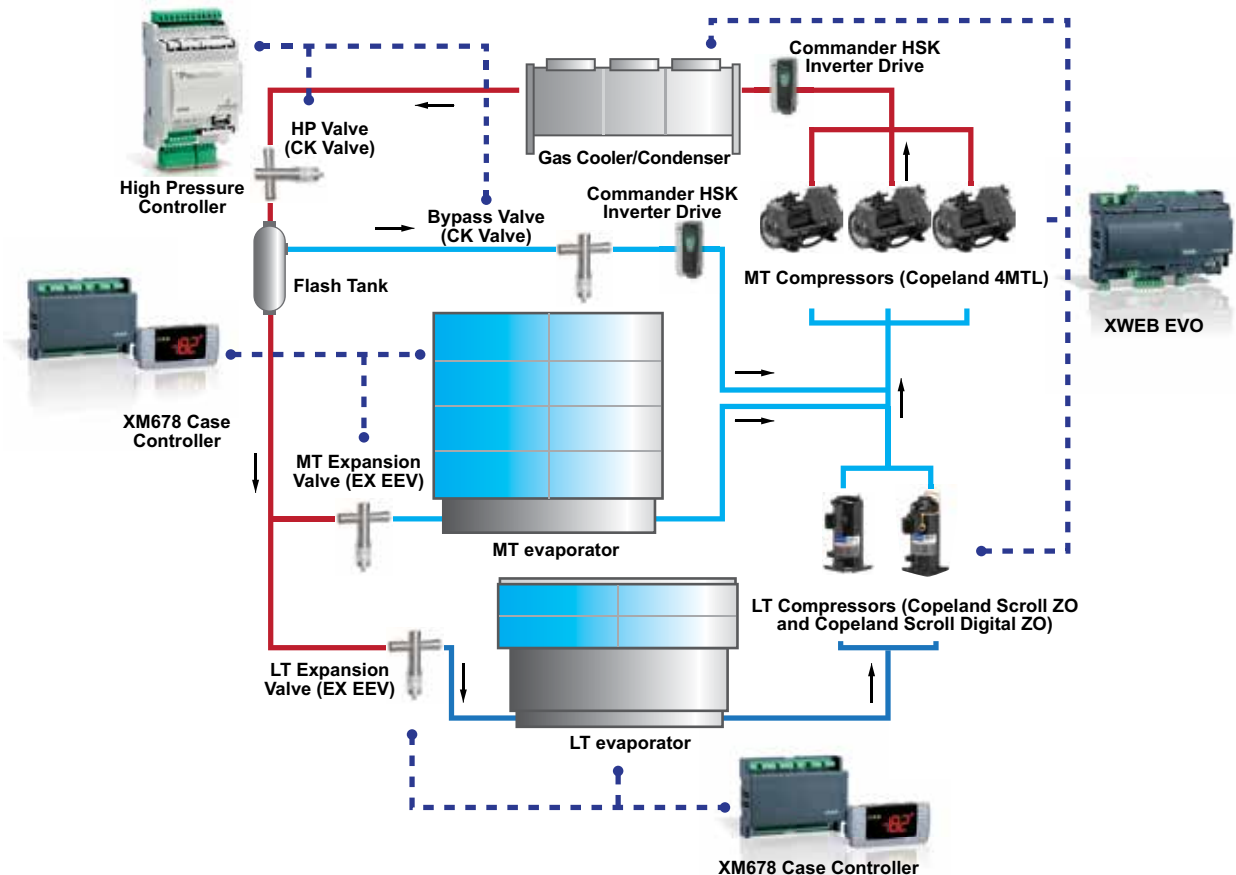

iPro HVAC and Lighting Controller

Offering proven strategies for energy savings in both lighting and HVAC systems, Emerson's iPro is the perfect solution for energy conscious small footprint retailers. Retailers can add additional rooftop unit capabilities using the IPEX60 expansion module. Access iPro parameters, perform schedule changes and enable ProAct™ monitoring and other remote services via the XWEB EVO supervisory platform.

- Features control for up to five lighting zones and two HVAC units
- Employs energy saving strategies for small format retailers
- Includes graphical display for on-site HVAC control and access to lighting configurations
- Access iPro parameters, perform schedule changes and enable ProAct monitoring and other remote services via the optional XWEB EVO supervisory platform

Lighting Control

- Allows users to combine scheduling with light level sensor technology to efficiently accommodate both indoor and outdoor needs
- Reduces energy consumption when programmed to dim or turn off lights in accordance with occupancy

HVAC Control

Controls up to two HVAC units to maintain a comfortable dining or shopping environment. An additional unit can be controlled with the IPEX69 Expansion module

- Facility operators can schedule setpoint offsets during times of low or no occupancy to reduce consumption. Each degree offset is equivalent to about 5% demand reduction.
- Utilizing the iPro's optional remote communication capabilities, retailers can adjust and maintain temperature setpoints without going on site.

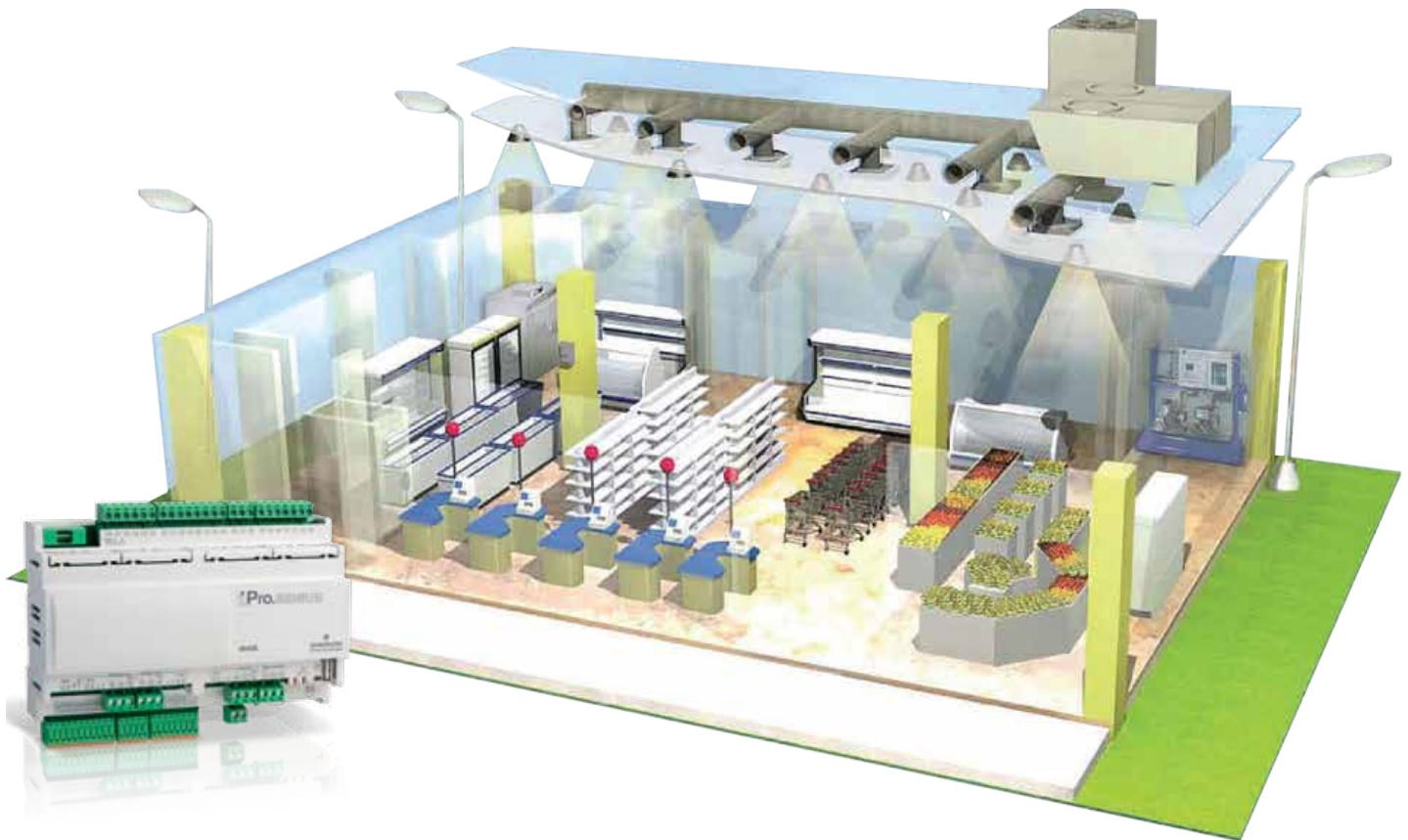

CoreSense™ Technology

iProRACK / XWEB EVO / E2

The communication feature of the CoreSense™ module provides access to information such as alarm history, operating parameters and the running status for a pack controller with open Modbus protocol.

It enables reset capability and remote monitoring of the compressor information with no requirement of actually visiting the site. An easy-to-access and user-friendly Retail Solutions web server interface for pack controller, Retail Solutions iProRack, allows customers to read the CoreSense information remotely with a graphical interface.

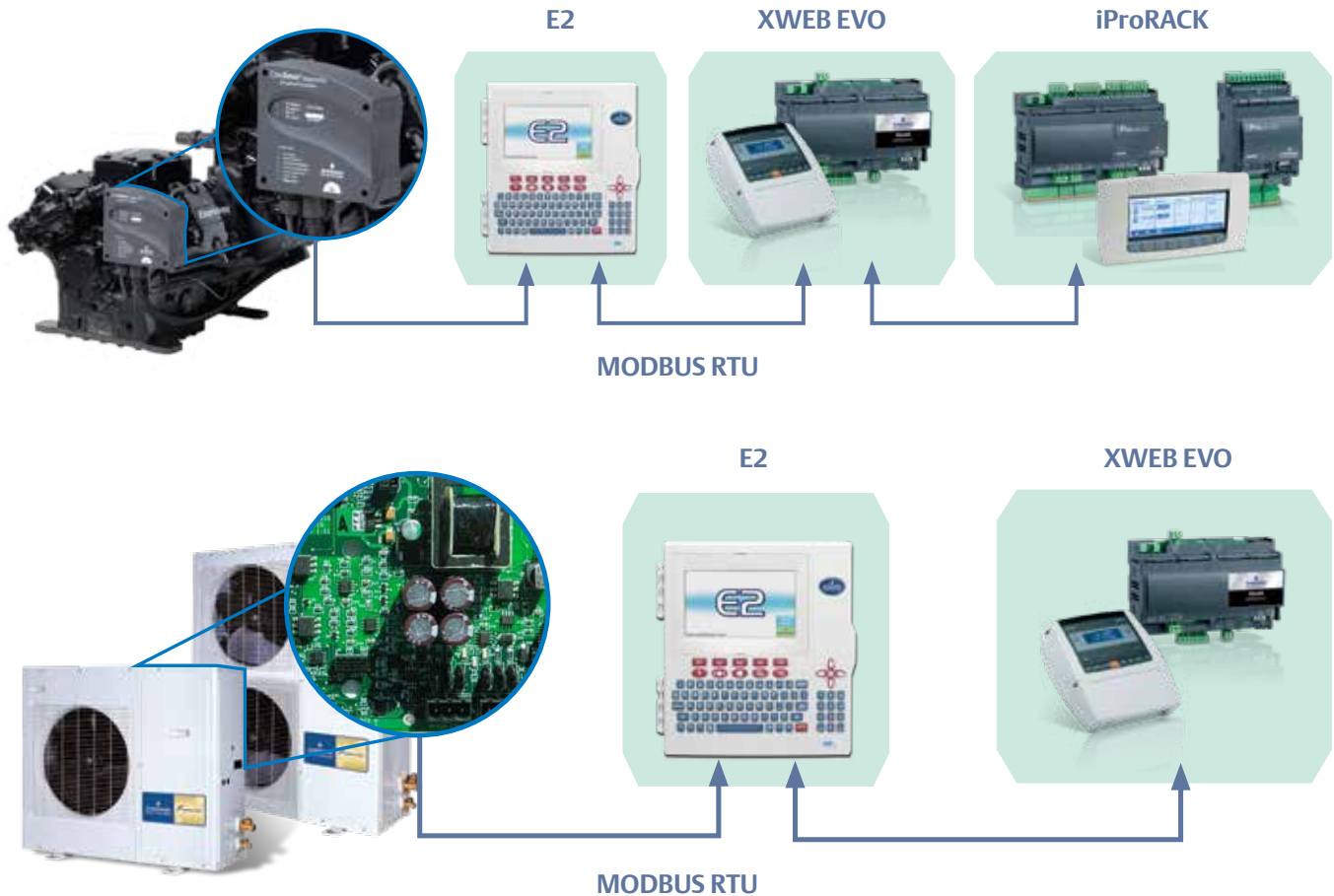

Emerson condensing units (CDU) are used for walk-in cooler and freezer applications. All units integrate the many benefits of Copeland™ Scroll Compressor Technology, Fans Speed Control and Copeland™ CoreSense Diagnostic Module.

Both XWEB EVO and E2 communicate with the condensing unit's One-way Communication Board via the RS485 MODBUS network. The XWEB EVO and E2 are used to receive alarm and notice status from the condensers via the One-way Communication board. If the CDU does not have a One-way Communication Board, one must be installed for XWEB EVO or E2 alarm and notice receiving. Either controller then provides the ability to assign delays and priorities to alarms or notices, but the alarms and notices can be logged in either the XWEB EVO or E2.

Notes

Contact List

Asia Pacific Headquarters

Emerson Commercial & Residential Solutions

Suite No. 2503-8, 25/F,
Exchange Tower, 33 Wang Chiu Road,
Kowloon Bay, Kowloon, Hong Kong
Tel: (852) 2866 3108
Fax: (852) 2520 6227

Australia

Emerson Commercial & Residential Solutions Australia Pty Ltd

356 Chisholm Road
Auburn NSW 2143, Australia
Tel: (61 2) 9795 2800
Fax: (61 2) 9738 1699

China - Suzhou

Emerson Commercial & Residential Solutions (Suzhou) Co. Ltd

No. 20 Building, Chuangtou Industrial Workshop Yang He Road, Loufeng North Area, Suzhou Industrial Park, Jiangsu 215122, P.R. China
Tel: (86 512) 8555 0607
Fax: (86 512) 8555 0620

India

Emerson Commercial & Residential Solutions (India) Ltd.

Delphi B-Wing, 601-602, 6th Floor,
Central Avenue, Pune 411 057,
Hiranandani Business Park, Powai,
Mumbai - 400 076 India
Tel: (91 22) 6662 0566
Fax: (91 22) 6662 0500

Indonesia

PT Emerson Indonesia

Wisma 46 - Kota BNI, 16th Floor, Suite 16.01, Jl. Jend.Sudirman Kav.1.
Jakarta 10220, Indonesia
Tel: (62 21) 29666242
Fax: (62 21) 29666245

Malaysia

Emerson Electric (M) Sdn. Bhd.

Level M2, Block A1 (239140-V),
Menara PKNS-PJ, Jalan Yong Shook Lin
46050 Petaling Jaya, Selangor, Malaysia
Tel: (603) 7949 9222
Fax: (603) 7949 9333

Philippines

Emerson Commercial & Residential Solutions

10/F SM Cyber West Avenue,
EDSA cor West Avenue, Barangay Bungad, Diliman, Quezon City 1105
Philippines
Tel: (632) 689 7200

South Korea

Emerson Commercial and Residential Solutions

3F POBA Gangnam Tower
343, Hakdong-ro, Gangnam-gu,
Seoul 135-820, Republic of Korea
Tel: (822) 3483 1500
Fax: (822) 592 7883

Taiwan

Emerson Commercial and Residential Solutions

3F No. 122 Lane 235,
Pao Chiau Rd., XinDian Dist.,
New Taipei City 23145, Taiwan (R.O.C.)
Tel: (8862) 8912 1360
Fax: (8862) 8912 1890

Thailand

Emerson Electric (Thailand) Ltd.

34/F., Interlink Tower
1858/133, Bangna-Trad Road
Bangna, Bangkok 10260, Thailand
Tel: (662) 716 4700
Fax: (662) 751 4241

Vietnam

Emerson Commercial & Residential Solutions

Level 6, Melinh Point Tower, 2 Ngo Due Ke,
District 1, Ho Chi Minh City Vietnam
Tel: (84) 908 009 189

Emerson.com/RetailSolutions

[P/N:CT02RE0118EN] Emerson is a trademark of Emerson Electric Co. ©2018 Emerson All rights reserved.

EMERSON. CONSIDER IT SOLVED.™